

EN 60601-1 Medical electrical equipment Part 1: General requirements for basic safety and essential performance	
Report Reference No.....:	SH11071329-001
Date of issue	Oct 19, 2011
Total number of pages.....:	167
Testing Laboratory	Intertek Testing Service Shanghai
Address	Building No.86, 1198 Qinzhou Road (North), Shanghai, China, 200233
Applicant's name.....:	TFE Hong Kong Limited
Address	7/F., Gemmy Factory Building, 12 Hung To Road, Kwun Tong, Kowloon, Hong Kong
Test specification:	
Standard	EN 60601-1: 2006
Test procedure.....:	Test Report
Non-standard test method.....:	N/A
Test Report Form No.....:	TTRF_EN_60601_1B
Test Report Form Originator	Intertek Testing Service Shanghai
Master TRF	Dated 2011-10
<p>Copyright © 2010 IEC System for Conformity Testing and Certification of Electrical Equipment (IECEE), Geneva, Switzerland. All rights reserved.</p> <p>This publication may be reproduced in whole or in part for non-commercial purposes as long as the IECEE is acknowledged as copyright owner and source of the material. IECEE takes no responsibility for and will not assume liability for damages resulting from the reader's interpretation of the reproduced material due to its placement and context.</p> <p>If this Test Report Form is used by non-IECEE members, the IECEE/IEC logo shall be removed</p> <p>This report is not valid as a CB Test Report unless signed by an approved CB Testing Laboratory and appended to a CB Test Certificate issued by an NCB in accordance with IECEE 02.</p>	
Test item description	Anti-Tamper Care Alarm
Trade Mark	N/A
Manufacturer	Same as applicant
Model/Type reference.....:	TS1011A, TS1011B, TS1012A, TS1012B, TS1013A, TS1013B
Ratings	Main unit is internally powered by four 1.5Vdc alkaline batteries IR remote control is internally powered by one 3Vdc button Lithium battery

Testing procedure and testing location:	
<input checked="" type="checkbox"/> Testing Laboratory:	Intertek Testing Service Shanghai
Testing location/ address	Building No.86, 1198 Qinzhou Road (North), Shanghai, China, 200233
<input type="checkbox"/> Associated Test Laboratory:	
Testing location/ address	
Tested by (name + signature).. :	Karl Zhong <i>Karl Zhong</i>
Approved by (+ signature)	Stan Wang <i>Stan</i>
<input type="checkbox"/> Testing procedure: TMP	
Tested by (name + signature).. :	
Approved by (+ signature)	
Testing location/ address	
<input type="checkbox"/> Testing procedure: WMT	
Tested by (name + signature).. :	
Witnessed by (+ signature)	
Approved by (+ signature)	
Testing location/ address	
<input type="checkbox"/> Testing procedure: SMT	
Tested by (name + signature).. :	
Approved by (+ signature)	
Supervised by (+ signature) :	
Testing location/ address	
<input type="checkbox"/> Testing procedure: RMT	
Tested by (name + signature).. :	
Approved by (+ signature)	
Supervised by (+ signature) :	
Testing location/ address	

List of Attachments (including a total number of pages in each attachment):

Photo of EUT (2 pages)

Summary of testing**Tests performed (name of test and test clause):**

All clauses

Testing location:Building No.86, 1198
Qinzhou Road (North),
Shanghai, China,
200233**Summary of compliance with National Differences**

List of countries addressed: N/A

The product fulfils the requirements of _____ (insert standard number and edition and delete the text in parenthesis or delete the whole sentence if not applicable)

Copy of marking plate

TFE Hong Kong Limited
Model: TS1011A
Battery:
1.5Vx4 AA or LR6 

TFE Hong Kong Limited
Model: TS1011B
Battery:
1.5Vx4 AA or LR6 

TFE Hong Kong Limited
Model: TS1012A
Battery:
1.5Vx4 AA or LR6 

TFE Hong Kong Limited
Model: TS1012B
Battery:
1.5Vx4 AA or LR6 

TFE Hong Kong Limited
Model: TS1013A
Battery:
1.5Vx4 AA or LR6 

TFE Hong Kong Limited
Model: TS1013B
Battery:
1.5Vx4 AA or LR6 

GENERAL INFORMATION	
Test item particulars (see also Clause 6):	
Classification of installation and use	: transportable / portable / stationary / mobile / fixed / permanently installed / hand-held
Device type (component/sub-assembly/ equipment/ system)	: Equipment
Intended use (Including type of patient, application location).....	: Intended for caregivers to be alerted when their patient is getting up from wheelchair or bed by themselves
Mode of operation	: Continuous / non-continuous
Supply connection	: internally powered / permanently installed / appliance coupler / non-detachable cord
Accessories and detachable parts included	: IR remote control
Other options include	: N/A
Testing	
Date of receipt of test item(s).....	: Jul 15, 2011
Dates tests performed	: Jul 15, 2011 to Oct 8, 2011
Possible test case verdicts:	
- test case does not apply to the test object	: N/A
- test object does meet the requirement	: Pass (P)
- test object was not evaluated for the requirement.....	: N/E
- test object does not meet the requirement	: Fail (F)
Abbreviations used in the report:	
- normal condition	: N.C.
- means of Operator protection	: MOOP
- single fault condition.....	: S.F.C.
- means of Patient protection	: MOPP
General remarks:	
<p>"(see Attachment #)" refers to additional information appended to the report. "(see appended table)" refers to a table appended to the report. The tests results presented in this report relate only to the object tested. This report shall not be reproduced except in full without the written approval of the testing laboratory. List of test equipment must be kept on file and available for review. Additional test data and/or information provided in the attachments to this report.</p>	
Throughout this report a <input type="checkbox"/> comma / <input checked="" type="checkbox"/> point is used as the decimal separator.	
Manufacturer's Declaration per sub-clause 6.2.5 of IEC60601-1:	
The application for obtaining a CB Test Certificate includes more than one factory location and a declaration from the Manufacturer stating that the sample(s) submitted for evaluation is (are) representative of the products from each factory has been provided.....	<input type="checkbox"/> Yes <input checked="" type="checkbox"/> Not applicable

When differences exist; they shall be identified in the General product information section.

Name and address of factory (ies)..... :

Same as applicant

General product information:

The product covered by this report is an Anti-Tamper Care Alarm equipment, intended for caregivers to be alerted when their patient is getting up from wheelchair or bed by themselves.

Main unit is internally powered by four 1.5Vdc alkaline batteries.

IR remote control is internally powered by one 3Vdc button Lithium battery.

Model similarity

All 6 types listed in this report are identical except small difference of optional accessories (like magnetic key) which have no impact on this evaluation

Following items are not included in this evaluation:

EMC (see report SH11071330-001)

Biocompatibility

Battery

Usability

RMF evaluation

PEMS

The product can be connected and powered by an adapter, but this function is not included in this evaluation. The product is considered as internally powered only in this evaluation.

IEC 60601-1			
Clause	Requirement + Test	Result - Remark	Verdict

INSULATION DIAGRAM

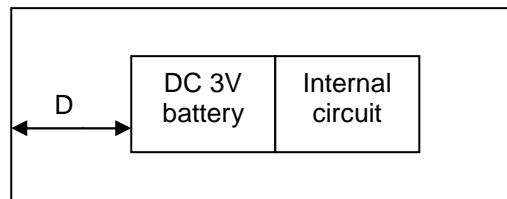
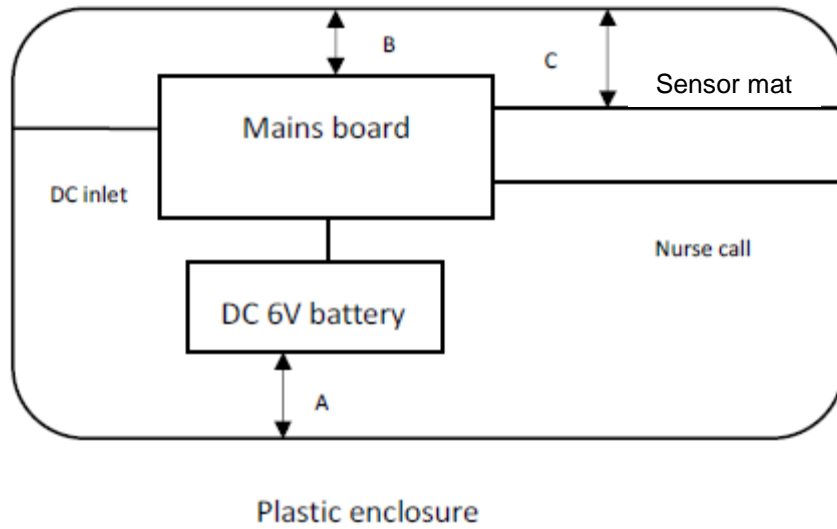

IR remote control

IEC 60601-1			
Clause	Requirement + Test	Result - Remark	Verdict

TABLE: To insulation diagram									P	
Pollution degree									2	—
Overvoltage category									N/A	—
Altitude.....									Up to 2000m	—
Additional details on parts considered as applied parts									<input checked="" type="checkbox"/> None <input type="checkbox"/> Areas _____ (See Clause 4.6 for details)	—
Area	Number and type of Means of Protection: MOOP, MOPP	CTI (IIIb, unless is known)	Working voltage		Required creepage (mm)	Required clearance (mm)	Measured creepage (mm)	Measured clearance (mm)	Remarks	
			Vrms	Vpk						
A	2MOPP	IIIb		6Vdc	3.4	1.6	8.5	8.5	Between battery holder and enclosure	
B	2MOPP	IIIb		6Vdc	3.4	1.6	9.5	9.5	Between PCB and enclosure	
C	2MOPP	IIIb		6Vdc	3.4	1.6	3.9	3.9	Between sensor mat connection and enclosure	
D	2MOPP	IIIb		3Vdc	3.4	1.6	>4.4	>4.4	Between battery holder and enclosure (IR remote control)	

INSULATION DIAGRAM CONVENTIONS and GUIDANCE:

A measured value must be provided in the value columns for the device under evaluation. The symbol > (greater than sign) must not be used. Switch-mode power supplies must be re-evaluated in the device under evaluation therefore N/A must not be used with a generic statement that the component is certified.

Insulation diagram is a graphical representation of equipment insulation barriers, protective impedance and protective earthing. If feasible, use the following conventions to generate the diagram:

- All isolation barriers are identified by letters between separate parts of diagram, for example separate transformer windings, optocouplers, wire insulation, creepage and clearance distances.
- Parts connected to earth with large dots are protectively earthed. Other connections to earth are functional
- Applied parts are extended beyond the equipment enclosure and terminated with an arrow.
- Parts accessible to the operator only are extended outside of the enclosure, but are not terminated with an arrow.

IEC 60601-1			
Clause	Requirement + Test	Result - Remark	Verdict
4	GENERAL REQUIREMENTS		P
4.1	Requirements of this standard applied in NORMAL USE and reasonably foreseeable misuse		P
4.2	A RISK MANAGEMENT PROCESS complying with ISO 14971 was performed	RMF check is not included in this evaluation	N/E
4.3	ESSENTIAL PERFORMANCE functions identified according to MANUFACTURER'S policy for RISK acceptability in RISK MANAGEMENT FILE.....	RMF check is not included in this evaluation	N/E
	ESSENTIAL PERFORMANCE functions maintained following particular tests as applicable		P
4.4	EXPECTED SERVICE LIFE stated in RISK MANAGEMENT FILE	RMF check is not included in this evaluation	N/E
4.5	Alternative means of addressing particular RISKS considered acceptable based on MANUFACTURER'S justification that RESIDUAL RISKS resulting from application of alternative means equal to or less than RESIDUAL RISKS resulting from requirements of this standard	No alternative means	N/A
4.6	RISK MANAGEMENT PROCESS identifies parts that can come into contact with PATIENT but not defined as APPLIED PARTS, subjected to the requirements for APPLIED PARTS, except for Clause 7.2.10.....	RMF check is not included in this evaluation	N/E
4.7	ME EQUIPMENT remained SINGLE FAULT SAFE, or the RISK remained acceptable as determined by Clause 4.2.....	RMF check is not included in this evaluation	N/E
	Failure of any one component at a time that could result in a HAZARDOUS SITUATION, including those in 13.1, simulated physically or theoretically	See Appended Table 13.2 for simulated physical test	P
	Risk associated with failure of component during EXPECTED SERVICE LIFE of ME EQUIPMENT taken into account to evaluate if a component should be subjected to failure simulation		P
4.8	All components and wiring whose failure could result in a HAZARDOUS SITUATION used according to their applicable ratings, except as specified, or by RISK MANAGEMENT PROCESS.....	RMF check is not included in this evaluation	N/E
	Reliability of components used as MEANS OF PROTECTION assessed for conditions of use in ME EQUIPMENT, and they complied with one of the following:		P
	a) Applicable safety requirements of a relevant IEC or ISO standard		P

IEC 60601-1			
Clause	Requirement + Test	Result - Remark	Verdict
	b) Requirements of this standard applied in the absence of a relevant IEC or ISO standard		P
4.9	A COMPONENT WITH HIGH-INTEGRITY CHARACTERISTICS provided because a fault in a particular component can generate an unacceptable RISK	RMF check is not included in this evaluation	N/E
	COMPONENTS WITH HIGH-INTEGRITY CHARACTERISTICS selected and evaluated consistent with their conditions of use and reasonable foreseeable misuse during EXPECTED SERVICE LIFE OF ME EQUIPMENT by reviewing RISK MANAGEMENT FILE	RMF check is not included in this evaluation	N/E
4.10	Power supply		
4.10.1	ME EQUIPMENT is suitable for connection to a SUPPLY MAINS, specified to be connected to a separate power supply, can be powered by an INTERNAL ELECTRICAL POWER SOURCE, or a combination of the three	Internally powered	P
4.10.2	Maximum rated voltage for ME EQUIPMENT intended to be connected to SUPPLY MAINS is 250 V for HAND-HELD ME EQUIPMENT (V)	Not hand-held	N/A
	– 250 V d.c. or single-phase a.c., or 500 V polyphase a.c. for ME EQUIPMENT and ME SYSTEMS with a RATED input ≤ 4 kVA (V)		P
	– 500 V for all other ME EQUIPMENT and ME SYSTEMS		N/A
4.11	Power input		
	Steady-state measured input of ME EQUIPMENT or ME SYSTEM at RATED voltage and at operating settings indicated in instructions for use did not exceed marked rating by more than 10% .. :	Internally powered	N/A
	– Measurements on ME EQUIPMENT or a ME SYSTEM marked with one or more RATED voltage ranges made at both upper and lower limits of the range	Internally powered	N/A
	Measurements made at a voltage equal to the mean value of the range when each marking of RATED input was related to the mean value of relevant voltage range	Internally powered	N/A
	Power input, expressed in volt-amperes, measured with a volt-ampere meter or calculated as the product of steady state current (measured as described above) and supply voltage	Internally powered	N/A

IEC 60601-1			
Clause	Requirement + Test	Result - Remark	Verdict
5	GENERAL REQUIREMENTS FOR TESTING ME EQUIPMENT		P
5.1	TYPE TESTS determined in consideration of Clause 4, in particular 4.2		P
	Test not performed when analysis indicated condition being tested was adequately evaluated by other tests or methods	Type test performed	N/A
	Results of RISK ANALYSIS used to determine combination(s) of simultaneous faults to be tested	RMF check is not included in this evaluation	N/E
5.2	TYPE TESTS conducted on one representative sample under investigation; multiple samples used simultaneously when validity of results was not significantly affected	Type test conducted on one representative sample	P
5.3	a) Tests conducted within the environmental conditions specified in technical description		P
	Temperature (°C), Relative Humidity (%)	10degC to 40degC, 30%RH to 90%RH	—
	Atmospheric Pressure (kPa)	700-1060	—
	b) ME EQUIPMENT shielded from other influences that might affect the validity of tests		P
	c) Test conditions modified and results adjusted accordingly when ambient temperature could not be maintained	See temperature test data	P
5.4	a) ME EQUIPMENT tested under least favourable working conditions specified in instructions for use and identified during RISK ANALYSIS, except as noted	RMF check is not included in this evaluation, least favourable working condition is according to IFU	P
	b) ME EQUIPMENT with adjustable or controlled operating values by anyone other than SERVICE PERSONNEL adjusted to values least favourable for the relevant test per instructions for use	No adjustable / controlled operating value	N/A
	c) When test results influenced by inlet pressure and flow or chemical composition of a cooling liquid, tests performed within the limits in technical description	No cooling liquid	N/A
	d) Potable water used for cooling	No water cooling	N/A
5.5	Supply voltage during tests was the least favourable of the voltages specified in 4.10 or voltages marked on ME EQUIPMENT (V)	Internally powered	N/A
	ME EQUIPMENT marked with a RATED frequency range tested at the least favourable frequency within the range (Hz).....	Powered by Vdc battery	N/A

IEC 60601-1			
Clause	Requirement + Test	Result - Remark	Verdict
	ME EQUIPMENT with more than one RATED voltage, or both a.c./ d.c. tested in conditions (see 5.4) related to the least favourable voltage, nature of supply, and type of current..... :	Only internally powered by Vdc battery	N/A
	ME EQUIPMENT tested with alternative ACCESSORIES and components specified in ACCOMPANYING DOCUMENTS to result in the least favourable conditions..... :	No alternative accessories / components	N/A
	ME EQUIPMENT connected to a separate power supply as specified in instructions for use	Internally powered	N/A
5.6	When failure occurred or probability of future failure detected during sequence of tests, per agreement with manufacturer, all tests affecting results conducted on a new sample	No such situation	N/A
	Alternatively, upon repair and modification of the sample, only the relevant tests conducted	No such situation	N/A
5.7	ME EQUIPMENT or parts thereof affected by climatic conditions were set up completely, or partially, with covers detached and subjected to a humidity preconditioning prior to tests of Clauses 8.7.4 and 8.8.3..... :	Humidity precondition performed according to 60601-1	P
	Manually detachable parts removed and treated concurrently with major parts and manually removable ACCESS COVERS were opened and detached		P
	ME EQUIPMENT heated to a temperature between T and T + 4 °C for at least 4 h and placed in a humidity chamber with a relative humidity of 93 % ± 3 % and an ambient within 2 °C of T in the range of + 20 °C to + 32 °C for 48 h		P
	When RISK MANAGEMENT PROCESS indicated ME EQUIPMENT can be exposed to high humidity for extended periods (i.e., out-door use), test time extended proportionally (h) :	No such situation	N/A
5.8	Unless stated otherwise, tests in this standard sequenced as in Annex B to prevent results of one test on a subsequent test		P
5.9	Determination of APPLIED PARTS and ACCESSIBLE PARTS		
5.9.1	APPLIED PARTS identified by inspection and reference to ACCOMPANYING DOCUMENTS :	Sensor mat, identified by inspection	P
5.9.2	ACCESSIBLE PARTS		
5.9.2.1	Accessibility, when necessary, determined using standard test finger of Fig 6 applied in a bent or straight position	No opening	N/A

IEC 60601-1			
Clause	Requirement + Test	Result - Remark	Verdict
	Openings preventing entry of test finger of Fig. 6 mechanically tested with a straight un-jointed test finger of the same dimensions with a force of 30 N	No opening	N/A
	When the straight un-jointed test finger entered, test with the standard test finger (Fig 6) was repeated, if necessary, by pushing the finger through the opening	No opening	N/A
5.9.2.2	Test hook of Fig. 7 inserted in all openings of ME EQUIPMENT and pulled with a force of 20 N for 10 s	No opening	N/A
	All additional parts that became accessible checked using standard test finger and by inspection	No opening	N/A
5.9.2.3	Conductive parts of actuating mechanisms of electrical controls accessible after removal of handles, knobs, levers and the like regarded as ACCESSIBLE PARTS	No such part	N/A
	Conductive parts of actuating mechanisms not considered ACCESSIBLE PARTS when removal of handles, knobs, etc. required use of a TOOL, and inspection of RISK MANAGEMENT FILE indicated the relevant part is unlikely to detach unintentionally during EXPECTED SERVICE LIFE OF ME EQUIPMENT	No such part	N/A

6	CLASSIFICATION OF ME EQUIPMENT AND ME SYSTEMS		P
6.2	CLASS I ME EQUIPMENT, externally powered	Internally powered	N/A
	CLASS II ME EQUIPMENT, externally powered	Internally powered	N/A
	INTERNALLY POWERED ME EQUIPMENT		P
	EQUIPMENT with means of connection to a SUPPLY MAINS complied with CLASS I or CLASS II ME EQUIPMENT requirements when so connected, and when not connected to SUPPLY MAINS with INTERNALLY POWERED ME EQUIPMENT requirements	Internally powered	N/A
	TYPE B APPLIED PART	Type B	P
	TYPE BF APPLIED PART	Type B	N/A
	TYPE CF APPLIED PART	Type B	N/A
	DEFIBRILLATION-PROOF APPLIED PARTS	Type B	N/A
6.3	ENCLOSURES classified according to degree of protection against ingress of water and particulate matter (IPN ₁ N ₂) as per IEC 60529	IP20	P

IEC 60601-1			
Clause	Requirement + Test	Result - Remark	Verdict
6.4	ME EQUIPMENT or its parts intended to be sterilized classified according to method(s) of sterilization in instructions for use..... :	Sterilization not required	N/A
6.5	ME EQUIPMENT and ME SYSTEMS intended for use in an OXYGEN RICH ENVIRONMENT classified for such use and complied with 11.2.2	Not intended for using an oxygen rich environment	N/A
6.6	CONTINUOUS or Non-CONTINUOUS OPERATION :	Continuous operation	P

7	ME EQUIPMENT IDENTIFICATION, MARKING, AND DOCUMENTS		P
7.1.1	RISK of poor USABILITY associated with the design of ME EQUIPMENT'S identification and marking addressed in a USABILITY ENGINEERING PROCESS..... :	Not evaluated in this report	N/E
7.1.2	Legibility of Markings Test for Markings specified in Clause 7.2-7.6..... :	See Appended Table 7.1.2	P
7.1.3	Required markings can be removed only with a TOOL or by appreciable force, are durable and remain CLEARLY LEGIBLE during EXPECTED SERVICE LIFE of ME EQUIPMENT in NORMAL USE		P
	a) After tests, adhesive labels didn't loosen up or curl up at edges and markings complied with requirements in Clause 7.1.2..... :	See appended Tables 7.1.3 and 8.10	P
	b) Markings required by 7.2-7.6 remained CLEARLY LEGIBLE after marking durability test ... :	See appended Tables 7.1.3 and 8.10	P
7.2	Marking on the outside of ME EQUIPMENT OR ME EQUIPMENT parts		P
7.2.1	At least markings in 7.2.2, 7.2.5, 7.2.6 (not for PERMANENTLY INSTALLED ME EQUIPMENT), 7.2.10, and 7.2.13 were applied when size of EQUIPMENT, its part, an ACCESSORY, or ENCLOSURE did not permit application of all required markings :	See attached copy of Marking Plate	P
	Remaining markings fully recorded in ACCOMPANYING DOCUMENTS :		P
	Markings applied to individual packaging when impractical to apply to ME EQUIPMENT	No such situation	N/A
	A material, component, ACCESSORY, or ME EQUIPMENT intended for a single use, or its packaging marked "Do Not Reuse" or with symbol 28 of Table D.1 (ISO 7000-1051, DB:2004-01)..... :	No such part	N/A
7.2.2	MANUFACTURER'S name or trademark marked on ME EQUIPMENT and detachable components..... :	See attached copy of Marking Plate	P
	Misidentification risk does not present an unacceptable risk	No misidentification	N/A

IEC 60601-1			
Clause	Requirement + Test	Result - Remark	Verdict
	MODEL OR TYPE REFERENCE also marked, except when misidentification would not present an unacceptable RISK..... :	See attached copy of Marking Plate	P
	Software forming part of a PEMS identified with a unique identifier, such as revision level or date of release/issue, and identification are available to designated persons :	Software check is not included in this evaluation	N/E
7.2.3	Symbol 11 on Table D.1 (ISO 7000-1641, DB: 2004-01) used, optionally, advice to OPERATOR to consult ACCOMPANYING DOCUMENTS	Such symbol not used	N/A
	Safety sign 10 on Table D.2 (safety sign IEC 60878 Safety 01) used, advising OPERATOR that ACCOMPANYING DOCUMENTS must be consulted	Such symbol not used	N/A
7.2.4	ACCESSORIES marked with name or trademark of MANUFACTURER or supplier, and with a MODEL or TYPE REFERENCE :	IR remote control is packed with main unit	N/A
	Markings applied to individual packaging when not practical to apply to ACCESSORIES	No such situation	N/A
7.2.5	MODEL OR TYPE REFERENCE of equipment to be connected to ME EQUIPMENT to provide power, is marked adjacent to the relevant connection point when this connection could result in an unacceptable RISK..... :	Such marking is provided But adapter is not included in this evaluation, EUT is considered as internally powered equipment	P
7.2.6	Connection to the Supply Mains		
	Except for PERMANENTLY INSTALLED ME EQUIPMENT, marking appearing on the outside of part containing SUPPLY MAINS connection and, adjacent to connection point	Internally powered	N/A
	For PERMANENTLY INSTALLED ME EQUIPMENT, NOMINAL supply voltage or range marked inside or outside of ME EQUIPMENT, preferably, adjacent to supply connection terminals	Internally powered	N/A
	– RATED supply voltage(s) or RATED voltage range(s) with a hyphen (-) between minimum and maximum voltages (V, V-V)..... :	Internally powered	N/A
	Multiple RATED supply voltages or multiple RATED supply voltage ranges are separated by (V/V).... :	Internally powered	N/A
	– Nature of supply (e.g., No. of phases, except single-phase) and type of current :	Internally powered	N/A
	Symbols 1-5, Table D.1 (symbols of IEC 60417-5032, 5032-1, 5032-2, 5031, and 5033, all DB: 2002-10) used, optionally, for same parameters:	Internally powered	N/A
	– RATED supply frequency or RATED frequency range in hertz..... :	Internally powered	N/A

IEC 60601-1			
Clause	Requirement + Test	Result - Remark	Verdict
	– Symbol 9 of Table D.1 (symbol IEC 60417-5172, DB: 2003-02) used for CLASS II ME EQUIPMENT	Internally powered	N/A
7.2.7	RATED input in amps or volt-amps, or in watts when power factor exceeds 0.9 (A, VA, W)	Internally powered	N/A
	RATED input for one or more RATED voltage ranges provided for upper and lower limits of the range or ranges when the range(s) is/are greater than $\pm 10\%$ of the mean value of specified range (A, VA,W)	Internally powered	N/A
	Input at mean value of range marked when range limits do not differ by more than 10 % from mean value (A, VA, W)	Internally powered	N/A
	Marking includes long-time and most relevant momentary volt-ampere ratings when provided, each plainly identified and indicated in ACCOMPANYING DOCUMENTS (VA)	Internally powered	N/A
	Marked input of ME EQUIPMENT provided with means for connection of supply conductors of other electrical equipment includes RATED and marked output of such means (A, VA, W)	Internally powered	N/A
7.2.8	Output connectors		
7.2.8.1	See 16.9.2.1 b) for MULTIPLE SOCKET-OUTLETS integral with ME EQUIPMENT	No output	N/A
7.2.8.2	Output connectors are marked, except for MULTIPLE SOCKET-OUTLETS or connectors intended for specified ACCESSORIES or equipment	No output	N/A
	Rated Voltage (V), Rated Current (A)	No output	—
	Rated Power (W), Output Frequency (Hz)	No output	—
7.2.9	ME EQUIPMENT or its parts marked with the IP environmental Code per IEC 60529 according to classification in 6.3 (Table D.3, Code 2)	Manufacturer consider the IP degree is IP0X, while it is IP20 according to evaluation of Intertek	N/A
7.2.10	Degrees of protection against electric shock as classified in 6.2 for all APPLIED PARTS marked with relevant symbols as follows (not applied to parts identified according to 4.6):		P
	TYPE B APPLIED PARTS with symbol 19 of Table D.1 (IEC 60417-5840, DB: 2002-10), not applied in such a way as to give the impression of being inscribed within a square in order to distinguish it from symbol IEC 60417-5333		P
	TYPE BF APPLIED PARTS with symbol 20 of Table D.1 (IEC 60417-5333, DB: 2002-10)	No such AP	N/A
	TYPE CF APPLIED PARTS with symbol 21 of Table D.1 (IEC 60417-5335, DB: 2002-10)	No such AP	N/A

IEC 60601-1			
Clause	Requirement + Test	Result - Remark	Verdict
	DEFIBRILLATION-PROOF APPLIED PARTS marked with symbols 25-27 of Table D.1 (IEC 60417-5841, IEC 60417-5334, or IEC 60417-5336, all DB: 2002-10):	No such AP	N/A
	Proper symbol marked adjacent to or on connector for APPLIED PART, except marked on APPLIED PART when there is no connector, or connector used for more than one APPLIED PART and different APPLIED PARTS with different classifications		P
	Safety sign 2 of Table D.2 (ISO 7010-W001) placed near relevant outlet when protection against effect of discharge of a cardiac defibrillator is partly in the PATIENT cable	No such protection	N/A
	An explanation indicating protection of ME EQUIPMENT against effects of discharge of a cardiac defibrillator depends on use of proper cables included in instructions for use	No such protection	N/A
7.2.11	ME EQUIPMENT not marked to the contrary assumed to be suitable for CONTINUOUS OPERATION		P
	DUTY CYCLE for ME EQUIPMENT intended for non-CONTINUOUS OPERATION appropriately marked to provide maximum "on" and "off" time	Continuous operation	N/A
7.2.12	Type and full rating of a fuse marked adjacent to ACCESSIBLE fuse-holder	No such fuse	N/A
	Fuse type.....	No such fuse	—
	Voltage (V) and Current (A) rating	No such fuse	—
	Operating speed (s) and Breaking capacity	No such fuse	—
7.2.13	A safety sign CLEARLY LEGIBLE and visible after INSTALLATION in NORMAL USE applied to a prominent location of EQUIPMENT that produce physiological effects capable of causing HARM to PATIENT or OPERATOR not obvious to OPERATOR ...	No such effect	N/A
	Nature of HAZARD and precautions for avoiding or minimizing the associated RISK described in instructions for use	No such effect	N/A
7.2.14	HIGH VOLTAGE TERMINAL DEVICES on the outside of ME EQUIPMENT accessible without the use of a TOOL marked with symbol 24 of Table D.1 (symbol IEC 60417-5036, DB: 2002-10)	No such HV part	N/A
7.2.15	Requirements for cooling provisions marked (e.g., supply of water or air).....	No cooling required	N/A
7.2.16	ME EQUIPMENT with limited mechanical stability	No limited mechanical stability	N/A
7.2.17	Packaging marked with special handling instructions for transport and/or storage.....	No special handling needed	N/A

IEC 60601-1			
Clause	Requirement + Test	Result - Remark	Verdict
	Permissible environmental conditions for transport and storage marked on outside of packaging	No special environmental conditions required	N/A
	Packaging marked with a suitable safety sign indicating premature unpacking of ME EQUIPMENT could result in an unacceptable RISK	No special requirement for packing	N/A
	Packaging of sterile ME EQUIPMENT or ACCESSORIES marked sterile	No sterilization required	N/A
7.2.18	RATED maximum supply pressure from an external source marked on ME EQUIPMENT adjacent to each input connector	No pressure input	N/A
7.2.19	Symbol 7 of Table D.1 (IEC 60417-5017, DB:2002-10) marked on FUNCTIONAL EARTH TERMINAL.....	No FE	N/A
7.2.20	Protective means, required to be removed to use a particular function of ME EQUIPMENT with alternate applications, marked to indicate the necessity for replacement when the function is no longer needed.....	No such means	N/A
	No marking applied when an interlock provided	No interlock	N/A
7.3	Marking on the inside of ME EQUIPMENT or ME EQUIPMENT parts		
7.3.1	Maximum power loading of heating elements or lamp-holders designed for use with heating lamps marked near or in the heater (W)	No such part	N/A
	A marking referring to ACCOMPANYING DOCUMENTS provided for heating elements or lamp-holders designed for heating lamps that can be changed only by SERVICE PERSONNEL using a TOOL	No such part	N/A
7.3.2	Symbol 24 of Table D.1 (symbol IEC 60417-5036, DB: 2002-10), or safety sign 3 of Table D.2 used to mark presence of HIGH VOLTAGE parts	No HV part	N/A
7.3.3	Type of battery and mode of insertion when applicable is marked	+/- marked	P
	An identifying marking provided referring to instructions in ACCOMPANYING DOCUMENTS for batteries intended to be changed only by SERVICE PERSONNEL using a TOOL	Battery is not intended only to be changed by service personnel using a tool	N/A
	A warning provided indicating replacement of lithium batteries or fuel cells when incorrect replacement by inadequately trained personnel would result in an unacceptable RISK (e.g., excessive temperatures, fire or explosion).....	No such risk (button lithium battery)	N/A
	An identifying marking also provided referring to instructions in ACCOMPANYING DOCUMENTS	RMF check is not included in this evaluation	N/E

IEC 60601-1			
Clause	Requirement + Test	Result - Remark	Verdict
7.3.4	Fuses, replaceable THERMAL CUT-OUTS and OVER-CURRENT RELEASES, accessible by use of a TOOL, marked by type and full rating at the component or by reference to ACCOMPANYING DOCUMENTS	No such part	N/A
	Type	No such part	—
	Voltage (V) and Current (A) rating	No such part	—
	Operating speed (s) and Breaking capacity	No such part	—
7.3.5	PROTECTIVE EARTH TERMINAL marked with symbol 6 of Table D.1 (IEC 60417-5019, DB: 2002-10), except for the PROTECTIVE EARTH TERMINAL in an APPLIANCE INLET according to IEC 60320-1	No PE	N/A
	Markings on or adjacent to PROTECTIVE EARTH TERMINALS not applied to parts requiring removal to make the connection, and remained visible after connection made	No PE	N/A
7.3.6	Symbol 7 of Table D.1 (IEC 60417-5017, DB: 2002 -10) marked on FUNCTIONAL EARTH TERMINALS	No FE	N/A
7.3.7	Terminals for supply conductors marked adjacent to terminals, except when no HAZARD would result when interchanging connections	Internally powered	N/A
	Terminal markings included in ACCOMPANYING DOCUMENTS when ME EQUIPMENT too small to accommodate markings	Internally powered	N/A
	Terminals exclusively for neutral supply conductor in PERMANENTLY INSTALLED ME EQUIPMENT marked with Code 1 of Table D.3 (Code in IEC 60445)	Internally powered	N/A
	Marking for connection to a 3-phase supply, if necessary, complies with IEC 60445	Internally powered	N/A
	Markings on or adjacent to electrical connection points not applied to parts requiring removal to make connection, and remained visible after connection made	Internally powered	N/A
7.3.8	“For supply connections, use wiring materials suitable for at least X °C” (where X > than max temperature measured in terminal box or wiring compartment under NORMAL USE), or equivalent, marked at the point of supply connections	Internally powered	N/A
	Statement not applied to parts requiring removal to make the connection, and CLEARLY LEGIBLE after connections made	Internally powered	N/A
7.4	Marking of controls and instruments		
7.4.1	The “on” & “off” positions of switch to control power to ME EQUIPMENT or its parts, including mains switch, marked with symbols 12 and 13 of Table D.1 (IEC 60417-5007, DB: 2002-10, and IEC 60417-5008, DB: 2002-10), or	Internally powered	N/A

IEC 60601-1			
Clause	Requirement + Test	Result - Remark	Verdict
	– indicated by an adjacent indicator light, or	Internally powered	N/A
	– indicated by other unambiguous means	Internally powered	N/A
	The “on/off” positions of push button switch with bi-stable positions marked with symbol 14 of Table D.1 (IEC 60417-5010 DB: 2002-10), and	Internally powered	N/A
	– status indicated by adjacent indicator light	Internally powered	N/A
	– status indicated by other unambiguous means	Internally powered	N/A
	The “on/off” positions of push button switch with momentary on position marked with symbol 15 of Table D.1 (symbol 60417-5011 DB: 2002-10), or	Internally powered	N/A
	– status indicated by adjacent indicator light	Internally powered	N/A
	– status indicated by other unambiguous means	Internally powered	N/A
7.4.2	Different positions of control devices/switches indicated by figures, letters, or other visual means		P
	Controls provided with an associated indicating device when change of setting of a control could result in an unacceptable RISK to PATIENT in NORMAL USE, or	No associated indicating device	N/A
	– an indication of direction in which magnitude of the function changes		P
7.4.3	Numeric indications of parameters on ME EQUIPMENT expressed in SI units according to ISO 31 except the base quantities listed in Table 1 expressed in the indicated units	No numeric indication	N/A
	ISO 1000 applied for application of SI units, their multiples, and certain other units	No numeric indication	N/A
	All Markings in Sub-clause 7.4 complied with tests and criteria of 7.1.2 and 7.1.3	No numeric indication	N/A
7.5	Safety signs		
	Markings used to convey a warning, prohibition or mandatory action mitigating a RISK not obvious to OPERATOR are safety signs from ISO 7010	No safety signs	N/A
	Affirmative statement together with safety sign placed in instructions for use if insufficient space on ME EQUIPMENT	No safety signs	N/A
	Specified colours in ISO 3864-1 used for safety signs	No safety signs	N/A
	Safety notices include appropriate precautions or instructions on how to reduce RISK(S)	No safety signs	N/A

IEC 60601-1			
Clause	Requirement + Test	Result - Remark	Verdict
	Safety signs including any supplementary text or symbols described in instructions for use	No safety signs	N/A
7.6	Symbols		
7.6.1	Meanings of symbols used for marking described in instructions for use..... :	See Appended Instruction for Use.	P
7.6.2	Symbols required by this standard conform to IEC or ISO publication referenced		P
7.6.3	Symbols used for controls and performance conform to the IEC or ISO publication where symbols are defined, as applicable	No symbol used for control	N/A
7.7	Colours of the insulation of conductors		
7.7.1	PROTECTIVE EARTH CONDUCTOR identified by green and yellow insulation	No PE	N/A
7.7.2	Insulation on conductors inside ME EQUIPMENT forming PROTECTIVE EARTH CONNECTIONS identified by green and yellow at least at terminations	No PE	N/A
7.7.3	Green and yellow insulation identify only following conductors:	Such color not used	N/A
	– PROTECTIVE EARTH CONDUCTORS	Such color not used	N/A
	– conductors specified in 7.7.2	Such color not used	N/A
	– POTENTIAL EQUALIZATION CONDUCTORS	Such color not used	N/A
	– FUNCTIONAL EARTH CONDUCTORS	Such color not used	N/A
7.7.4	Neutral conductors of POWER SUPPLY CORDS are “light blue” specified in IEC 60227-1 or IEC 60245-1	No power supply cord	N/A
7.7.5	Colours of conductors in POWER SUPPLY CORDS in accordance with IEC 60227-1 or IEC 60245-1	No power supply cord	N/A
7.8	Indicator lights and controls		
7.8.1	Red indicator lights mean: Warning (i.e., immediate response by OPERATOR required)	Low battery	P
	Yellow indicator lights mean: Caution (i.e., prompt response by OPERATOR required)	Alert	P
	Green indicator lights mean: Ready for use		P
	Other colours, if used: Meaning other than red, yellow, or green (colour, meaning)..... :	No other color used	N/A
7.8.2	Red used only for emergency control	No emergency control	N/A
7.9	ACCOMPANYING DOCUMENTS		
7.9.1	ME EQUIPMENT accompanied by documents containing at least instructions for use, and a technical description		P

IEC 60601-1			
Clause	Requirement + Test	Result - Remark	Verdict
	ACCOMPANYING DOCUMENTS identify ME EQUIPMENT by the following, as applicable:		P
	– Name or trade-name of MANUFACTURER and an address the RESPONSIBLE ORGANIZATION can be referred to	Name and address of manufacturer provided	P
	– MODEL OR TYPE REFERENCE	Type reference provided	P
	When ACCOMPANYING DOCUMENTS provided electronically (e.g., on CDROM), RISK MANAGEMENT PROCESS includes instructions as to what is required in hard copy or as markings on ME EQUIPMENT (for emergency operation)	Paper copy will be provided	N/A
	ACCOMPANYING DOCUMENTS specify special skills, training, and knowledge required of OPERATOR or RESPONSIBLE ORGANIZATION and environmental restrictions on locations of use	No special skill, training and knowledge required Environmental requirement provided	P
	ACCOMPANYING DOCUMENTS written at a level consistent with education, training, and other needs of individuals for whom they are intended		P
7.9.2	Instructions for use include the required information		
7.9.2.1	– intended use of ME EQUIPMENT,		P
	– frequently used functions, and		P
	– known contraindication(s) to use of ME EQUIPMENT	No such contraindication	N/A
	Classifications as in Clause 6, all markings per Clause 7.2, and explanation of safety signs and symbols marked on ME EQUIPMENT		P
	Instructions for use are in a language acceptable to the intended operator		P
7.9.2.2	Instructions for use include all warning and safety notices		P
	Warning statement for CLASS I ME EQUIPMENT indicating: “WARNING: To avoid risk of electric shock, this equipment must only be connected to a supply mains with protective earth”	Not class I	N/A
	Warnings regarding significant RISKS of reciprocal interference posed by ME EQUIPMENT during specific investigations or treatments	No such risk	N/A
	Information on potential electromagnetic or other interference and advice on how to avoid or minimize such interference		P
	Warning statement for ME EQUIPMENT supplied with an integral MULTIPLE SOCKET-OUTLET indicating, “connecting electrical equipment to MSO effectively leads to creating an ME SYSTEM, and can result in a reduced level of safety”	No multiple socket-outlet	N/A

IEC 60601-1			
Clause	Requirement + Test	Result - Remark	Verdict
	The RESPONSIBLE ORGANIZATION is referred to this standard for the requirements applicable to ME SYSTEMS	Not medical system	N/A
7.9.2.3	Statement on ME EQUIPMENT for connection to a separate power supply indicating "power supply is specified as a part of ME EQUIPMENT or combination is specified as a ME SYSTEM"	No such power supply	N/A
7.9.2.4	Warning statement for mains- operated ME EQUIPMENT with additional power source not automatically maintained in a fully usable condition indicating the necessity for periodic checking or replacement of power source	Not mains operated	N/A
	Warning to remove primary batteries when ME EQUIPMENT is not likely to be used for some time when leakage from battery would result in an unacceptable RISK..... :	RMF check is not included in this evaluation	N/E
	Specifications of replaceable INTERNAL ELECTRICAL POWER SOURCE when provided	Requirement of battery provided	P
	Warning indicating ME EQUIPMENT must be connected to an appropriate power source when loss of power source would result in an unacceptable RISK..... :	Internally powered	N/A
7.9.2.5	Instructions for use include a description of ME EQUIPMENT, its functions, significant physical and performance characteristics together with the expected positions of OPERATOR, PATIENT, or other persons near ME EQUIPMENT in NORMAL USE		P
	Information provided on materials and ingredients PATIENT or OPERATOR is exposed to when such exposure can constitute an unacceptable RISK	No such risk	N/A
	Restrictions specified on other equipment or NETWORK/DATA COUPLINGS, other than those forming part of an ME SYSTEM, to which a SIGNAL INPUT/OUTPUT PART may be connected		P
	APPLIED PARTS specified	IFU indicates the sensor mat to be used with patient	P
7.9.2.6	Information provided indicating where the installation instructions may be found or information on qualified personnel who can perform the installation	No installation requirement	N/A
7.9.2.7	Instructions provided indicating not to position ME EQUIPMENT to make it difficult to operate the disconnection device when an APPLIANCE COUPLER or separable plug is used as isolation means to meet 8.11.1 a)	No appliance coupler / plug	N/A

IEC 60601-1			
Clause	Requirement + Test	Result - Remark	Verdict
7.9.2.8	Necessary information provided for OPERATOR to bring ME EQUIPMENT into operation including initial control settings, and connection to or positioning of PATIENT prior to use of ME EQUIPMENT, its parts, or ACCESSORIES		P
7.9.2.9	Information provided to operate ME EQUIPMENT including explanation of controls, displays and signals, sequence of operation, connection of detachable parts or ACCESSORIES, replacement of material consumed during operation		P
	Meanings of figures, symbols, warning statements, abbreviations and indicator lights described in instructions for use		P
7.9.2.10	A list of all system messages, error messages, and fault messages provided with an explanation of messages including important causes and possible action(s) to be taken to resolve the problem indicated by the message	No error messages provided	N/A
7.9.2.11	Information provided for the OPERATOR to safely terminate operation of ME EQUIPMENT		P
7.9.2.12	Information provided on cleaning, disinfection, and sterilization methods, and applicable parameters that can be tolerated by ME EQUIPMENT parts or ACCESSORIES specified		P
	Components, ACCESSORIES or ME EQUIPMENT marked for single use, except when required by MANUFACTURER to be cleaned, disinfected, or sterilized prior to use	No single use part	N/A
7.9.2.13	Instructions provided on preventive inspection, calibration, maintenance and its frequency	Such activity not needed	N/A
	Information provided for safe performance of routine maintenance necessary to ensure continued safe use of ME EQUIPMENT	Such activity not needed	N/A
	Parts requiring preventive inspection and maintenance to be performed by SERVICE PERSONNEL identified including periods of application	Such activity not needed	N/A
	Instructions provided to ensure adequate maintenance of ME EQUIPMENT containing rechargeable batteries to be maintained by anyone other than SERVICE PERSONNEL	Such activity not needed	N/A
7.9.2.14	A list of ACCESSORIES, detachable parts, and materials for use with ME EQUIPMENT provided		P
	Other equipment providing power to ME SYSTEM sufficiently described (e.g. part number, RATED VOLTAGE, max or min power, protection class, intermittent or continuous service)	No such equipment	N/A

IEC 60601-1			
Clause	Requirement + Test	Result - Remark	Verdict
7.9.2.15	RISKS associated with disposal of waste products, residues, etc., and of ME EQUIPMENT and ACCESSORIES at the end of their EXPECTED SERVICE LIFE are identified, and instructions provided on minimizing these RISKS	See IFU, page 7	P
7.9.2.16	Instructions for use include information specified in 7.9.3 or identify where it can be found (e.g. in a service manual)		P
7.9.3	Technical description		
7.9.3.1	All essential data provided for safe operation, transport, storage, and measures or conditions necessary for installing ME EQUIPMENT, and preparing it for use including the following:		P
	– information as in clause 7.2		P
	– permissible environmental conditions of use including conditions for transport and storage		P
	– all characteristics of ME EQUIPMENT including range(s), accuracy, and precision of displayed values or where they can be found	No such value	N/A
	– special installation requirements such as max. permissible apparent impedance of SUPPLY MAINS	No installation required	N/A
	– permissible range of values of inlet pressure and flow, and chemical composition of cooling liquid used for cooling	No cooling required	N/A
	– a description of means of isolating ME EQUIPMENT from SUPPLY MAINS, when such means not in ME EQUIPMENT	No such means	N/A
	– a description of means for checking oil level in partially sealed oil filled ME EQUIPMENT or its parts when applicable	No oil	N/A
	– a warning statement addressing HAZARDS that can result from unauthorized modification of ME EQUIPMENT according to following examples		P
	“WARNING: No modification of this equipment is allowed”		P
	“WARNING: Do not modify this equipment without authorization of the manufacturer”		N/A
	“WARNING: If this equipment is modified, appropriate inspection and testing must be conducted to ensure continued safe use of equipment”		N/A
	Technical description separable from instructions for use contains required information, as follows		
	– information as in clause 7.2	No separate technical description	N/A

IEC 60601-1			
Clause	Requirement + Test	Result - Remark	Verdict
	– all applicable classifications in Clause 6, warning and safety notices, and explanation of safety signs marked on ME EQUIPMENT	No separate technical description	N/A
	– a brief description of ME EQUIPMENT, how it functions, and its significant physical and performance characteristics	No separate technical description	N/A
	MANUFACTURER'S optional requirements for minimum qualifications of SERVICE PERSONNEL documented in technical description	No separate technical description	N/A
7.9.3.2	The technical description contains the following required information		
	–type and full rating of fuses used in SUPPLY MAINS external to PERMANENTLY INSTALLED ME EQUIPMENT, when type and rating of fuses are not apparent from information on RATED current and mode of operation of ME EQUIPMENT	Internally powered	N/A
	– a statement for ME EQUIPMENT with a non-DETACHABLE POWER SUPPLY CORD if POWER SUPPLY CORD is replaceable by SERVICE PERSONNEL, and if so, instructions for correct connection and anchoring to ensure compliance with 8.11.3	No such part	N/A
	– instructions for correct replacement of interchangeable or detachable parts specified by MANUFACTURER as replaceable by SERVICE PERSONNEL, and	No such part	N/A
	– warnings identifying nature of HAZARD when replacement of a component could result in an unacceptable RISK, and when replaceable by SERVICE PERSONNEL all information necessary to safely replace the component	No such part	N/A
7.9.3.3	Technical description indicates, MANUFACTURER will provide circuit diagrams, component part lists, descriptions, calibration instructions to assist to SERVICE PERSONNEL in parts repair	No repairable part	N/A
7.9.3.4	Means used to comply with requirements of 8.11.1 clearly identified in technical description	Internally powered	N/A

8	PROTECTION AGAINST ELECTRICAL HAZARDS FROM ME EQUIPMENT		
8.1	Limits specified in Clause 8.4 not exceeded for ACCESSIBLE PARTS and APPLIED PARTS in NORMAL or SINGLE FAULT CONDITIONS		P
	NORMAL CONDITION considered as simultaneous occurrence of situations identified in 8.1a)		P
	SINGLE FAULT CONDITION considered to include the occurrences as specified in Clause 8.1b)... :		P
	ACCESSIBLE PARTS determined according to 5.9		P
	LEAKAGE CURRENTS measured according to 8.7		P

IEC 60601-1			
Clause	Requirement + Test	Result - Remark	Verdict
8.2	Requirements related to power sources		
8.2.1	When ME EQUIPMENT specified for connection to a separate power source other than SUPPLY MAINS, separate power source considered as part of ME EQUIPMENT or combination considered as an ME SYSTEM	No such power source	N/A
	Tests performed with ME EQUIPMENT connected to separate power supply when one specified	No such power source	N/A
	When a generic separate power supply specified, specification in ACCOMPANYING DOCUMENTS examined	No such power source	N/A
8.2.2	No HAZARDOUS SITUATION other than absence of ESSENTIAL PERFORMANCE developed when a connection with wrong polarity made for ME EQUIPMENT from an external d.c. source	No external DC source	N/A
	ME EQUIPMENT connected with correct polarity did not present an unacceptable RISK	No external DC source	N/A
	Protective devices that can be reset by anyone without a TOOL restore correct operation on reset	No external DC source	N/A
8.3	Classification of APPLIED PARTS		
	a) APPLIED PART specified in ACCOMPANYING DOCUMENTS as suitable for DIRECT CARDIAC APPLICATION is TYPE CF	No such AP	N/A
	b) An APPLIED PART provided with a PATIENT CONNECTION intended to deliver electrical energy or an electrophysiological signal to or from PATIENT is TYPE BF or CF APPLIED PART	No such AP	N/A
	c) An APPLIED PART not covered by a) or b) is a TYPE B, BF, or CF	Type B	P
	d) Requirements of a TYPE B APPLIED PART applied to a part in 4.6 to be subjected to requirements for an APPLIED PART (except marking)	No such part	N/A
	Requirements for a TYPE BF or CF APPLIED PART applied as in RISK MANAGEMENT PROCESS	Type B	N/A
8.4	Limitation of voltage, current or energy		
8.4.1	PATIENT CONNECTIONS intended to deliver Current		
	Limits in 8.4.2 not applied to currents intended to flow through body of PATIENT to produce a physiological effect during NORMAL USE	No such patient connection	N/A
8.4.2	ACCESSIBLE PARTS including APPLIED PARTS		

IEC 60601-1			
Clause	Requirement + Test	Result - Remark	Verdict
	a) Currents from, to, or between PATIENT CONNECTIONS did not exceed limits for PATIENT LEAKAGE CURRENT and PATIENT AUXILIARY CURRENT per Tables 3 and 4 when measured according to Clause 8.7.4..... :	See appended Table 8.7	P
	b) LEAKAGE CURRENTS from, to, or between ACCESSIBLE PARTS did not exceed limits for TOUCH CURRENT in Cl. 8.7.3 c) when measured per Clause 8.7.4 (Ma)..... :	See appended Table 8.7	P
	c) Limits specified in b) not applied to parts when probability of a connection to a PATIENT, directly or through body of OPERATOR, is negligible in NORMAL USE, and the OPERATOR is appropriately instructed	No such situation	N/A
	– accessible contacts of connectors	No such part	N/A
	– contacts of fuseholders accessible during replacement of fuse	No such part	N/A
	– contacts of lampholders accessible after removal of lamp	No such part	N/A
	– parts inside an ACCESS COVER that can be opened without a TOOL, or where a TOOL is needed but the instructions for use instruct an OPERATOR other than SERVICE PERSONNEL to open the relevant ACCESS COVER	Battery (1.5Vdc, 4pcs) Battery compartment cover can not be opened without tool, but manual doesn't prohibit operator other than service personnel to open the cover	P
	Voltage to earth or to other ACCESSIBLE PARTS did not exceed 42.4 V peak a.c. or 60 V d.c. for above parts in NORMAL or single fault condition (V a.c. or d.c.)..... :	See appended Table 8.4.2	P
	Limit of 60 V d.c. applied with no more than 10% peak-to-peak ripple, and when ripple larger than specified value, 42.4 V peak limit applied (V d.c.)..... :	See appended Table 8.4.2	P
	Energy did not exceed 240 VA for longer than 60 s or stored energy available did not exceed 20 J at a potential up to 2 V (VA or J)..... :	See appended Table 8.4.2	P
	LEAKAGE CURRENT limits referred to in 8.4.2 b) applied when voltages higher than limits in 8.4.2 c) were present (Ma)..... :	Voltage is not over limit	N/A
	d) Voltage and energy limits specified in c) above also applied to the following:		P
	– internal parts, other than contacts of plugs, connectors and socket-outlets, touchable by test pin in Fig 8 inserted through an opening in an ENCLOSURE; and	No such part	N/A

IEC 60601-1			
Clause	Requirement + Test	Result - Remark	Verdict
	– internal parts touchable by a metal test rod with a diameter of 4 mm and a length of 100 mm, inserted through any opening on top of ENCLOSURE or through any opening provided for adjustment of pre-set controls using a TOOL	No such part	N/A
	Test pin or the test rod inserted through relevant openings with minimal force of no more than 1 N		P
	Test rod inserted in every possible position through openings provided for adjustment of pre-set controls that can be adjusted in NORMAL USE, with a force of 10 N	No such part	N/A
	Test repeated with a TOOL specified in instructions for use	No such part	N/A
	Test rod freely and vertically suspended through openings on top of ENCLOSURE	No such part	N/A
	e) Devices used to de-energize parts when an ACCESS COVER opened without a TOOL gives access to parts at voltages above levels permitted by this Clause comply with 8.11.1 for mains isolating switches and remain effective in SINGLE FAULT CONDITION	Tool needed to open battery compartment cover No other cover	N/A
	A TOOL is required when it is possible to prevent the devices from operating	Tool needed to open battery compartment cover No other cover	N/A
8.4.3	Worst case voltage between pins of plug and between either supply pin and ENCLOSURE did not exceed 60 V one s after disconnecting the plug of ME EQUIPMENT or its parts (V)	No plug	N/A
	A triggering circuit used to ensure disconnection occurred at peak of supply voltage waveform	No plug	N/A
	When voltage exceeded 60 V, calculated or measured stored charge didn't exceed 45 Mc.. :	No plug	N/A
8.4.4	Residual voltage of conductive parts of capacitive circuits, having become accessible after ME EQUIPMENT was de-energized after removal of ACCESS COVERS, didn't exceed 60V or calculated stored charge didn't exceed 45Mc.. :	No such part	N/A
	A device manually discharging capacitors used when automatic discharging was not possible and ACCESS COVERS could be removed only with aid of a TOOL	No such part	N/A
	Capacitor(s) and connected circuitry marked with symbol 24 of Table D.1 (IEC 60417-5036, DB: 2002-10), and manual discharging device specified in technical description..... :	No such part	N/A

IEC 60601-1			
Clause	Requirement + Test	Result - Remark	Verdict
8.5	Separation of parts		
8.5.1	MEANS OF PROTECTION (MOP)		
8.5.1.1	Two MEANS of PROTECTION provided for ME EQUIPMENT to prevent APPLIED and other ACCESSIBLE PARTS from exceeding limits in 8.4		P
	Each MEANS OF PROTECTION categorized as a MEANS OF PATIENT PROTECTION or a MEANS OF OPERATOR PROTECTION, taking into account Clause 4.6, and flow chart in Fig A.12		P
	Varnishing, enamelled, oxidation, and similar protective finishes and coatings with sealing compounds replasticizing at temperatures expected during operation and sterilization disregarded as MEANS OF PROTECTION		P
	Coatings and other insulation intended as a MEANS OF PROTECTION complying with IEC 60950-1:2001 considered acceptable as a MEANS OF OPERATOR PROTECTION but not automatically as a MEANS OF PATIENT PROTECTION	No MOP considered according to IEC 60950-1	N/A
	RISK MANAGEMENT PROCESS taken into consideration for MEANS OF PATIENT PROTECTION	RMF check is not included in this evaluation	N/E
	Components and wiring forming a MEANS OF PROTECTION comply with 8.10		P
	Insulation, CREEPAGE, CLEARANCES, components or earth connections not complying with 8.5.1.2 and 8.5.1.3 not considered as MEANS OF PROTECTION, and failure of these parts regarded as NORMAL CONDITION		P
8.5.1.2	MEANS OF PATIENT PROTECTION (MOPP)		
	Solid insulation forming a MEANS OF PATIENT PROTECTION complied with dielectric strength test of Clause 8.8 at test voltage of Table 6		P
	CREEPAGE and CLEARANCES forming a MEANS OF PATIENT PROTECTION complied with Table 12		P
	PROTECTIVE EARTH CONNECTIONS forming a MEANS OF PATIENT PROTECTION complied with Cl. 8.6	No PE	N/A
	A Y1 capacitor complying with IEC 60384-14 and having passed dielectric strength test for two MEANS OF PATIENT PROTECTION considered equivalent to one MEANS OF PATIENT PROTECTION	No such part	N/A
	Two capacitors used in series, each RATED for total WORKING VOLTAGE across the pair and have the same NOMINAL capacitance	No such part	N/A
	Voltage _{Total Working} (V) and C _{Nominal} (μF) :	No such part	—
8.5.1.3	MEANS OF OPERATOR PROTECTION (MOOP)		

IEC 60601-1			
Clause	Requirement + Test	Result - Remark	Verdict
	Solid insulation forming a MEANS OF OPERATOR PROTECTION complied with:	No insulation considered as MOOP	N/A
	– dielectric strength test of 8.8 at test voltage of Table 6; or	No insulation considered as MOOP	N/A
	– requirements of IEC 60950-1 for INSULATION CO-ORDINATION	No insulation considered as MOOP	N/A
	CREEPAGE and CLEARANCES forming a MEANS OF OPERATOR PROTECTION complied with:	No insulation considered as MOOP	N/A
	– limits of Tables 13 to 16 (inclusive); or	No insulation considered as MOOP	N/A
	– requirements of IEC 60950-1 for INSULATION CO-ORDINATION	No insulation considered as MOOP	N/A
	PROTECTIVE EARTH CONNECTIONS forming a MEANS OF OPERATOR PROTECTION complied with Cl. 8.6, or	No insulation considered as MOOP	N/A
	– requirements and tests of IEC 60950-1 for protective earthing	No insulation considered as MOOP	N/A
	A Y2 capacitor complying with IEC 60384-14 and passing dielectric strength test for one MEANS OF OPERATOR PROTECTION considered equivalent to one MEANS OF OPERATOR PROTECTION	No insulation considered as MOOP	N/A
	A Y1 capacitor complying with IEC 60384-14 and having passed dielectric strength test for two MEANS OF OPERATOR PROTECTION considered equivalent to two MEANS OF OPERATOR PROTECTION	No insulation considered as MOOP	N/A
	Two capacitors used in series each RATED for total WORKING VOLTAGE across the pair and have the same NOMINAL capacitance	No insulation considered as MOOP	N/A
	Voltage_{Total Working} (V) and C_{Nominal} (μF)	No insulation considered as MOOP	—
	Points at which impedances of components, CREEPAGE, CLEARANCES, PROTECTIVE EARTH CONNECTIONS or insulation, prevent ACCESSIBLE PARTS from exceeding limits in 8.4 examined whether a failure at any of these points is to be regarded as a NORMAL or SINGLE FAULT CONDITION	No insulation considered as MOOP	N/A
	A MEANS OF PROTECTION protecting APPLIED PARTS, or parts identified by 4.6 as parts subject to the same requirements, considered MEANS OF PATIENT PROTECTION.....	No insulation considered as MOOP	N/A
	A MEANS OF PROTECTION protecting other parts considered MEANS OF OPERATOR PROTECTION	No insulation considered as MOOP	N/A
8.5.2	Separation of PATIENT CONNECTIONS		

IEC 60601-1			
Clause	Requirement + Test	Result - Remark	Verdict
8.5.2.1	PATIENT CONNECTIONS of F-TYPE APPLIED PART separated from all other parts by equivalent to one MEANS OF PATIENT PROTECTION for a WORKING VOLTAGE equal to maximum MAINS VOLTAGE and complied with limit for PATIENT LEAKAGE CURRENT at 110 % of max. MAINS VOLTAGE :	No F-type AP	N/A
	Separation requirement not applied between multiple functions of a single F-TYPE APPLIED PART	No F-type AP	N/A
	PATIENT CONNECTIONS treated as one APPLIED PART in the absence of electrical separation between PATIENT CONNECTIONS of same or another function	No F-type AP	N/A
	MANUFACTURER has defined if multiple functions are to be considered as all within one APPLIED PART or as multiple APPLIED PARTS . :	No F-type AP	N/A
	Classification as TYPE BF, CF, or DEFIBRILLATION-PROOF applied to one entire APPLIED PART	No F-type AP	N/A
	LEAKAGE CURRENT tests conducted per 8.7.4 :	No F-type AP	N/A
	Dielectric strength test conducted per 8.8.3.... :	No F-type AP	N/A
	CREEPAGE and CLEARANCES measured per 8.9 and Tables 11 to 16 as applicable	No F-type AP	N/A
	A protective device connected between PATIENT CONNECTIONS of an F-TYPE APPLIED PART and ENCLOSURE to protect against excessive voltages did not operate below 500 V r.m.s	No F-type AP	N/A
8.5.2.2	PATIENT CONNECTIONS of a TYPE B APPLIED PART not PROTECTIVELY EARTHED are separated by one MEANS OF PATIENT PROTECTION from metal ACCESSIBLE PARTS not PROTECTIVELY EARTHED :		P
	– except when metal ACCESSIBLE PART is physically close to APPLIED PART and can be regarded as a part of APPLIED PART; and	No such structure	N/A
	– RISK that metal ACCESSIBLE PART will make contact with a source of voltage or LEAKAGE CURRENT above permitted limits is acceptably low	RMF check is not included in this evaluation	N/E
	LEAKAGE CURRENT tests conducted per 8.7.4 :		P
	Dielectric strength test conducted per 8.8.3.... :		P
	Relevant CREEPAGE and CLEARANCES measured per 8.9 and Tables 11 to 16 as applicable		P
	The RISK MANAGEMENT FILE reviewed	RMF check is not included in this evaluation	N/E

IEC 60601-1			
Clause	Requirement + Test	Result - Remark	Verdict
8.5.2.3	A connector on a PATIENT lead located at the end of the lead remote from PATIENT, with conductive part not separated from all PATIENT CONNECTIONS by one MEANS OF PATIENT PROTECTION for a WORKING VOLTAGE equal to MAXIMUM MAINS VOLTAGE		
	- cannot be connected to earth or hazardous voltage while the PATIENT CONNECTIONS are in contact with PATIENT	No patient lead	N/A
	- conductive part of connector not separated from all PATIENT CONNECTIONS did not come into contact with a flat conductive plate of not less than 100 mm diameter	No patient lead	N/A
	- CLEARANCE between connector pins and a flat surface is at least 0.5 mm	No patient lead	N/A
	- conductive part pluggable into a mains socket protected from making contact with parts at MAINS VOLTAGE by insulation with a CREEPAGE DISTANCE of at least 1.0 mm, a 1500 V dielectric strength and complying with 8.8.4.1	No patient lead	N/A
	- required test finger did not make electrical contact with conductive part when applied against access openings with a force of 10 N, except when RISK MANAGEMENT PROCESS indicated no unacceptable RISK existed from contact with objects other than a mains socket or a flat surface	No patient lead	N/A
8.5.3	MAXIMUM MAINS VOLTAGE		
	- MAXIMUM MAINS VOLTAGE determined to be the highest RATED supply voltage for single-phase or d.c. SUPPLY MAINS powered ME EQUIPMENT, as well as INTERNALLY POWERED ME EQUIPMENT with a means of connection to a SUPPLY MAINS (V).....	No mains connection	N/A
	When less than 100 V, MAXIMUM MAINS VOLTAGE was 250 V	No mains connection	N/A
	- MAXIMUM MAINS VOLTAGE was the highest RATED phase to neutral supply voltage for poly-phase ME EQUIPMENT (V)	No mains connection	N/A
	- for other INTERNALLY POWERED ME EQUIPMENT, maximum mains voltage was 250 V	Max. mains voltage considered as 250V	P
8.5.4	WORKING VOLTAGE		
	- Input supply voltage to ME EQUIPMENT was RATED voltage or voltage within RATED range resulting in highest measured value (V)	Internally powered	N/A
	- WORKING VOLTAGE for d.c. voltages with superimposed ripple was average value when peak-to-peak ripple less than 10% of average value or peak voltage when peak-to-peak ripple exceeding 10% of average value (V).....	Internally powered	N/A

IEC 60601-1			
Clause	Requirement + Test	Result - Remark	Verdict
	– WORKING VOLTAGE for each MEANS OF PROTECTION forming DOUBLE INSULATION was voltage DOUBLE INSULATION, as a whole, subjected to (V)..... :	See Insulation Diagram and Insulation Table	P
	– Intentional or accidental earthing of PATIENT regarded as a NORMAL CONDITION for WORKING VOLTAGE involving a PATIENT CONNECTION not connected to earth		P
	– WORKING VOLTAGE between PATIENT CONNECTIONS of an F-TYPE APPLIED PART and ENCLOSURE was highest voltage appearing across insulation in NORMAL USE including earthing of any part of APPLIED PART (V)..... :	No F-type AP	N/A
	– WORKING VOLTAGE for DEFIBRILLATION-PROOF APPLIED PARTS determined disregarding possible presence of defibrillation voltages	No such AP	N/A
	– WORKING VOLTAGE was equal to resonance voltage in case of motors provided with capacitors between the point where a winding and a capacitor are connected together and a terminal for external conductors (V)..... :	No motor	N/A
8.5.5	DEFIBRILLATION-PROOF APPLIED PARTS		
8.5.5.1	Classification “DEFIBRILLATION-PROOF APPLIED PART” applied to one APPLIED PART in its entirety, but not separate functions of same APPLIED PART	No such AP	N/A
	Possibility of an OPERATOR receiving a shock from such parts taken into consideration in RISK MANAGEMENT PROCESS	No such AP	N/A
	Isolation of PATIENT CONNECTIONS of a DEFIBRILLATION-PROOF APPLIED PART from other parts of ME EQUIPMENT accomplished as follows:	No such AP	N/A
	a) No hazardous electrical energies appear during a discharge of cardiac defibrillator	No such AP	N/A
	b) ME EQUIPMENT complied with relevant requirements of this standard, providing BASIC SAFETY and ESSENTIAL PERFORMANCE following exposure to defibrillation voltage, and recovery time stated in ACCOMPANYING DOCUMENTS	No such AP	N/A
8.5.5.2	Means provided to limit energy delivered to a 100 Ω load to at least 90% of energy delivered to this load with ME EQUIPMENT disconnected .. :	No such AP	N/A
8.6	Protective and functional earthing and potential equalization of ME EQUIPMENT		
8.6.1	Requirements of 8.6.2 to 8.6.8 applied	No earthing	N/A

IEC 60601-1			
Clause	Requirement + Test	Result - Remark	Verdict
	Parts complying with IEC 60950-1 for protective earthing and serving as MEANS OF OPERATOR PROTECTION but not PATIENT PROTECTION exempted from requirements of 8.6.2 to 8.6.8	No earthing	N/A
8.6.2	PROTECTIVE EARTH TERMINAL is suitable for connection to an external protective earthing system by a PROTECTIVE EARTH CONDUCTOR in a POWER SUPPLY CORD and a suitable plug or by a FIXED PROTECTIVE EARTH CONDUCTOR..... :	No earthing	N/A
	Clamping means of PROTECTIVE EARTH TERMINAL of ME EQUIPMENT for FIXED supply conductors or POWER SUPPLY CORDS comply with 8.11.4.3, and cannot be loosened without TOOL	No earthing	N/A
	Screws for internal PROTECTIVE EARTH CONNECTIONS completely covered or protected against accidental loosening from outside..... :	No earthing	N/A
	Earth pin of APPLIANCE INLET forming supply connection to ME EQUIPMENT regarded as PROTECTIVE EARTH TERMINAL	No earthing	N/A
	PROTECTIVE EARTH TERMINAL not used for mechanical connection between different parts of ME EQUIPMENT or securing components not related to protective or functional earthing	No earthing	N/A
8.6.3	PROTECTIVE EARTH CONNECTION not used for a moving part, except when MANUFACTURER demonstrated in RISK MANAGEMENT FILE connection will remain reliable during EXPECTED SERVICE LIFE	No earthing	N/A
8.6.4	a) PROTECTIVE EARTH CONNECTIONS carried fault currents reliably and without excessive voltage drop	No earthing	N/A
	b) Allowable TOUCH CURRENT and PATIENT LEAKAGE CURRENT in SINGLE FAULT CONDITION were not exceeded, when impedance of PROTECTIVE EARTH CONNECTIONS exceeded values in 8.6.4 a) and Table 8.6.4, due to limited current capability of relevant circuits	No earthing	N/A
8.6.5	Surface coatings		
	Poorly conducting surface coatings on conductive elements removed at the point of contact	No such structure	N/A
	Coating not removed when requirements for impedance and current-carrying capacity met	No such structure	N/A
8.6.6	Plugs and sockets		

IEC 60601-1			
Clause	Requirement + Test	Result - Remark	Verdict
	PROTECTIVE EARTH CONNECTION where connection between SUPPLY MAINS and ME EQUIPMENT or between separate parts of ME EQUIPMENT made via a plug and socket was made before and interrupted after supply connections	No earthing	N/A
	- applied also where interchangeable parts are PROTECTIVELY EARTHED	No earthing	N/A
8.6.7	Terminal for connection of a POTENTIAL EQUALIZATION CONDUCTOR		
	– Terminal is accessible to OPERATOR with ME EQUIPMENT in any position of NORMAL USE	No potential equalization conductor	N/A
	– RISK of accidental disconnection minimized in NORMAL USE	No potential equalization conductor	N/A
	– Terminal allows conductor to be detached without a TOOL	No potential equalization conductor	N/A
	– Terminal not used for a PROTECTIVE EARTH CONNECTION	No potential equalization conductor	N/A
	– Terminal marked with symbol 8 of Table D.1 (i.e., symbol IEC 60417-5021)	No potential equalization conductor	N/A
	– Instructions for use contain information on function and use of POTENTIAL EQUALIZATION CONDUCTOR together with a reference to requirements of this standard	No potential equalization conductor	N/A
	POWER SUPPLY CORD does not incorporate a POTENTIAL EQUALIZATION CONDUCTOR	No potential equalization conductor	N/A
8.6.8	FUNCTIONAL EARTH TERMINAL not used to provide a PROTECTIVE EARTH CONNECTION	No earthing	N/A
8.6.9	Class II ME EQUIPMENT		
	Third conductor of POWER SUPPLY CORD connected to protective earth contact of MAINS PLUG provided with CLASS II ME EQUIPMENT with isolated internal screens used as functional earth connection to the screen's FUNCTIONAL EARTH TERMINAL, coloured green and yellow	No such structure	N/A
	Two MEANS OF PROTECTION provided by insulation of internal screens and all internal wiring connected to them with a related explanation in technical description	No such structure	N/A
8.7	LEAKAGE CURRENTS and PATIENT AUXILIARY CURRENTS		
8.7.1	a) Electrical isolation providing protection against electric shock limits currents to values in 8.7.3..... :	See appended Tables 8.7	P
	b) Specified values of EARTH LEAKAGE, TOUCH, PATIENT LEAKAGE, and PATIENT AUXILIARY CURRENTS applied in combination of conditions in appended Table 8.7	See appended Tables 8.7	P

IEC 60601-1			
Clause	Requirement + Test	Result - Remark	Verdict
8.7.2	Allowable values specified in 8.7.3 applied under SINGLE FAULT CONDITIONS of 8.1 b), except		P
	– where insulation used in conjunction with a PROTECTIVE EARTH CONNECTION, insulation short circuited only under conditions in 8.6.4 b)	No earthing	N/A
	– the only SINGLE FAULT CONDITION for EARTH LEAKAGE CURRENT was interruption of one supply conductor at a time	No earthing	N/A
	– LEAKAGE CURRENTS and PATIENT AUXILIARY CURRENT not measured in SINGLE FAULT CONDITION of short circuiting of one constituent part of DOUBLE INSULATION		P
	SINGLE FAULT CONDITIONS not applied at same time as special test conditions of MAXIMUM MAINS VOLTAGE on APPLIED PARTS and non-PROTECTIVELY EARTHED parts of ENCLOSURE		P
8.7.3	Allowable Values		
	a) Allowable values in 8.7.3 b), c), and d) measured based on, and are relative to currents in Fig 12 a), or by a device measuring frequency contents of currents as in Fig 12 b. :	See appended Table 8.7	P
	b) Allowable values of PATIENT LEAKAGE and AUXILIARY CURRENTS are according to Tables 3 & 4, and values of a.c. are relative to currents having a frequency not less than 0.1Hz :	See appended Table 8.7	P
	c) TOUCH CURRENT did not exceed 100 Ma in NORMAL CONDITION and 500 Ma in SINGLE FAULT CONDITION (I_{TNC} , I_{TSFC})..... :	See appended Table 8.7	P
	d) EARTH LEAKAGE CURRENT did not exceed 5 Ma in NORMAL CONDITION and 10 Ma in SINGLE FAULT CONDITION (I_{ENC} , I_{ESFC}) :	No earthing	N/A
	Higher values of EARTH LEAKAGE CURRENT permitted for PERMANENTLY INSTALLED ME EQUIPMENT connected to a supply circuit supplying only this ME EQUIPMENT according to local regulations or IEC 60364-7-710 :	No earthing	N/A
	e) LEAKAGE CURRENTS, regardless of waveform and frequency, did not exceed 10 Ma r.m.s. in NORMAL or in SINGLE FAULT CONDITION (measured with a non-frequency-weighted device :	See appended Table 8.7	P
8.7.4	LEAKAGE and PATIENT AUXILIARY CURRENTS measurements :	See appended Table 8.7	P
8.8	Insulation		

IEC 60601-1			
Clause	Requirement + Test	Result - Remark	Verdict
8.8.1	Insulation relied on as MEANS OF PROTECTION, including REINFORCED INSULATION and insulation between parts of opposite polarity of MAINS PART ON SUPPLY MAINS side of mains fuse or OVER-CURRENT RELEASE	No mains input	P
	Insulation exempted from test (complies with clause 4.8)		P
	Insulation forming MEANS OF OPERATOR PROTECTION and complying with IEC 60950-1 for INSULATION CO-ORDINATION not tested as in 8.8	Insulation is considered and evaluated as MOPP	N/A
8.8.2	Distance through solid insulation or use of thin sheet material		
	Solid insulation forming SUPPLEMENTARY or REINFORCED INSULATION for a PEAK WORKING VOLTAGE greater than 71 V provided with:	No such structure (no 71V voltage)	N/A
	a) 0.4 mm, min, distance through insulation, or	No such structure	N/A
	b) does not form part of an ENCLOSURE and not subject to handling or abrasion during NORMAL USE, and comprised of:	No such structure	N/A
	– at least two layers of material, each passed the appropriate dielectric strength test, or	No such structure	N/A
	– three layers of material, for which all combinations of two layers together passed the appropriate dielectric strength test	No such structure	N/A
	Dielectric strength test for one or two layers was same as for one MEANS OF PROTECTION for SUPPLEMENTARY INSULATION	No such structure	N/A
	Dielectric strength test for one or two layers was same as for two MEANS OF PROTECTION for REINFORCED INSULATION	No such structure	N/A
	BASIC, SUPPLEMENTARY, and REINFORCED INSULATION required between windings of wound components separated by interleaved insulation complying with a) or b), or both, except when	No such structure	N/A
	c) Wire with solid insulation, other than solvent based enamel, complying with a)	No such structure	N/A
	d) Wire with multi-layer extruded or spirally wrapped insulation complying with b) and complying with Annex L	No such structure	N/A
	e) Finished wire with spirally wrapped or multi-layer extruded insulation, complying with Annex L	No such structure	N/A
	– BASIC INSULATION: minimum two wrapped layers or one extruded layer	No such structure	N/A
	– SUPPLEMENTARY INSULATION: minimum two layers, wrapped or extruded	No such structure	N/A

IEC 60601-1			
Clause	Requirement + Test	Result - Remark	Verdict
	– REINFORCED INSULATION: minimum three layers, wrapped or extruded	No such structure	N/A
	In d) and e), for spirally wrapped insulation with CREEPAGE DISTANCES between layers less than in Table 12 or 16 (Pollution Degree 1) depending on type of insulation, path between layers sealed as a cemented joint in 8.9.3.3 and test voltages of TYPE TESTS in L.3 equal 1.6 times of normal values	No such structure	N/A
	Protection against mechanical stress provided where two insulated wires or one bare and one insulated wire are in contact inside wound component, crossing at an angle between 45° and 90° and subject to winding tension..... :	No such structure	N/A
	Finished component complied with routine dielectric strength tests of 8.8.3..... :	No such structure	N/A
	Tests of Annex L not repeated since material data sheets confirm compliance..... :	No such structure	N/A
8.8.3	Dielectric Strength		
	Solid insulating materials with a safety function withstood dielectric strength test voltages	See appended Table 8.8.3	P
8.8.4	Insulation other than wire insulation		
8.8.4.1	Resistance to heat retained by all insulation and insulating partition walls during EXPECTED SERVICE LIFE OF ME EQUIPMENT		P
	ME EQUIPMENT and RISK MANAGEMENT FILE examined in conjunction with resistance to moisture, dielectric strength, and mechanical strength tests	RMF check is not included in this evaluation	N/E
	Satisfactory evidence of compliance provided by manufacturer for resistance to heat..... :	Ball pressure test performed	N/A
	Tests conducted in absence of satisfactory evidence for resistance to heat..... :		P
	a) ENCLOSURE and other external parts of insulating material, except insulation of flexible cords and parts of ceramic material, subjected to ball-pressure test using apparatus of Fig 21	See Table 8.8.4.1	P
	b) Parts of insulating material supporting uninsulated parts of MAINS PART subjected to ball-pressure test in a), except at 125 °C ± 2 °C or ambient indicated in technical description ±2°C plus temperature rise determined during test of 11.1 of relevant part, if higher (°C)	No mains part	N/A

IEC 60601-1			
Clause	Requirement + Test	Result - Remark	Verdict
	Test not performed on parts of ceramic material, insulating parts of commutators, brush-caps, and similar, and on coil formers not used as REINFORCED INSULATION	No such part	N/A
8.8.4.2	Resistance to environmental stress		
	Insulating characteristics and mechanical strength of all MEANS OF PROTECTION not likely to be impaired by environmental stresses including deposition of dirt resulting from wear of parts within EQUIPMENT, potentially reducing CREEPAGE and CLEARANCES below 8.9		P
	Ceramic and similar materials not tightly sintered, and beads alone not used as SUPPLEMENTARY OF REINFORCED INSULATION	No such material	N/A
	Insulating material with embedded heating conductors considered as one MEANS OF PROTECTION but not two MEANS OF PROTECTION	No such structure	N/A
	Parts of natural latex rubber aged by suspending samples freely in an oxygen cylinder containing commercial oxygen to a pressure of 2.1 Mpa \pm 70 kPa, with an effective capacity of at least 10 times volume of samples	No such material	N/A
	There were no cracks visible to naked eyes after samples kept in cylinder at 70 $^{\circ}$ C \pm 2 $^{\circ}$ C for 96h, and afterwards, left at room temperature for at least 16h	No such material	N/A
8.9	CREEPAGE DISTANCES and AIR CLEARANCES		
8.9.1.1	CREEPAGE DISTANCES and AIR CLEARANCES are \geq to values in Tables 11 to 16 (inclusive), except as specified in Clauses 8.9.1.2 to 8.9.1.15		P
8.9.1.2	Tables 11 to 16 (inclusive) not applied to CREEPAGE and CLEARANCES forming MEANS OF OPERATOR PROTECTION per IEC 60950-1 for INSULATION CO-ORDINATION and used under conditions compliance was tested	Insulation is not evaluated according to IEC 60950-1	N/A
8.9.1.3	Specified min CLEARANCE applied as min CREEPAGE for CREEPAGE DISTANCES across glass, mica, ceramic and other inorganic insulating materials with similar tracking characteristics	No such material	N/A
8.9.1.4	When min CREEPAGE derived from Tables 11 to 16 (inclusive) was less than min applicable CLEARANCE, value of min CLEARANCE applied as min CREEPAGE DISTANCE	No such situation	N/A
8.9.1.5	ME EQUIPMENT RATED to operate at an altitude of 2000 m		P
	ME EQUIPMENT RATED to operate at an altitude specified by MANUFACTURER (m)	No altitude specified	N/A

IEC 60601-1			
Clause	Requirement + Test	Result - Remark	Verdict
	Operating altitude corresponding to actual air pressure for ME EQUIPMENT intended for pressurized environments (e.g., aircraft) used to determine multiplication factor from Table 8, and AIR CLEARANCE was multiplied by this factor	No such operating altitude, such factor not used	N/A
	CREEPAGE DISTANCES not subjected to multiplication factors, but were at least as large as the resulting value for AIR CLEARANCE	Such multiplication factor not used	N/A
8.9.1.6	When WORKING VOLTAGE was between those in Tables 11 to 16 (inclusive), CREEPAGE and CLEARANCES calculated as follows:		P
	– CREEPAGE DISTANCES determined by linear interpolation between the nearest two values, and the calculated spacing rounded off to the next higher 0.1 mm increment (mm)..... :	See Insulation Diagram/Table.	P
	– CLEARANCES for PEAK WORKING VOLTAGES above 2800 V peak or d.c. determined by linear interpolation between the nearest two values, and the calculated spacing rounded off to the next higher 0.1 mm increment (mm)..... :	No such high voltage	N/A
	– for AIR CLEARANCES corresponding to PEAK WORKING VOLTAGE up to 2800 V peak or d.c., the higher of the two values applied		P
8.9.1.7	Material groups classified in accordance with Table 9 (Material Group)..... :	See Insulation Diagram/Table.	P
	Material group evaluated using 50 drops of solution A based on test data for material according to IEC 60112	IIIb for unknown material	N/A
	Material of unknown group considered IIIb		P
8.9.1.8	– Pollution degree 1: Micro-environment sealed to exclude dust and moisture	Pollution degree 2	N/A
	– Pollution degree 2: Micro-environment with non-conductive pollution, except occasional conductivity caused by condensation		P
	– Pollution degree 3: Micro-environment subject to conductive pollution, or dry non-conductive pollution that could become conductive due to expected condensation	Pollution degree 2	N/A
	– Pollution degree 4: Micro-environment where continuous conductivity occurs due to conductive dust, rain, or other wet conditions	Pollution degree 2	N/A
	Pollution degree 4 not used for insulation providing a MEANS OF PROTECTION	Pollution degree 2	N/A
	Where insulation between MAINS PART and earth might be compromised, measures such as maintenance ensure that micro-environment is mitigated to a lower pollution degree	No mains no earthing	N/A

IEC 60601-1			
Clause	Requirement + Test	Result - Remark	Verdict
8.9.1.9	Overvoltage category classification; value of MAINS TRANSIENT VOLTAGE determined from overvoltage category per IEC60664-1 and NOMINAL a.c. MAINS VOLTAGE using Table 10	No mains	N/A
	V_{MT} Peak (V)	No mains	—
	V_{MN} r.m.s (V)	No mains	—
8.9.1.10	AIR CLEARANCE for MAINS PARTS (operating on RATED MAINS VOLTAGES up to 300 V) were values for r.m.s. or d.c. RATED MAINS VOLTAGE in Table 13 plus additional CLEARANCE in Table 14 for PEAK WORKING VOLTAGE	No mains	N/A
8.9.1.11	SUPPLY MAINS overvoltage category II applied according to IEC 60664-1	No mains	N/A
	For ME EQUIPMENT intended for overvoltage category III, Tables 13 to 15 (inclusive) not used for clearance, instead values in the next MAINS TRANSIENT VOLTAGE column upwards used	No mains	N/A
	When PATIENT protection (Table 12) is required for use of ME EQUIPMENT on overvoltage category III SUPPLY MAINS, guidance provided on values required in the rationale for Cl. 8.9 used	No mains	N/A
8.9.1.12	A SECONDARY CIRCUIT derived from a SUPPLY MAINS, normally, considered to be overvoltage category I according to IEC 60664-1 when the MAINS PART is overvoltage category II (Table 15)	No mains	N/A
	Table 15 applied to earthed SECONDARY CIRCUIT OR INTERNALLY POWERED ME EQUIPMENT	Insulation is considered and evaluated as MOPP	N/A
	Requirements for primary circuits in Tables 13 and 14 used for an unearthed SECONDARY CIRCUIT derived from a SUPPLY MAINS	Insulation is considered and evaluated as MOPP	N/A
	Table 15 applied when SECONDARY CIRCUIT was separated from MAINS PART by a functionally earthed or PROTECTIVELY EARTHED metal screen or transients in SECONDARY CIRCUIT were below the levels expected for overvoltage category I	Insulation is considered and evaluated as MOPP	N/A
	Table 15 column for circuits not subject to transient overvoltages applied to:	Insulation is considered and evaluated as MOPP	N/A
	– d.c. SECONDARY CIRCUITS reliably connected to earth and have capacitive filtering limiting peak-to-peak ripple to 10 % of d.c. voltage, and	Insulation is considered and evaluated as MOPP	N/A
	– circuits in INTERNALLY POWERED ME EQUIPMENT	Insulation is considered and evaluated as MOPP	N/A
8.9.1.13	For PEAK WORKING VOLTAGES above 1400 V peak or d.c. Table 15 not applied since all the following conditions were met:	No such high voltage	N/A
	– CLEARANCE was at least 5 mm	No such high voltage	N/A

IEC 60601-1			
Clause	Requirement + Test	Result - Remark	Verdict
	– insulation complied with dielectric strength test of 8.8.3 using an a.c. test voltage with an r.m.s. value equal to 1.06 times PEAK WORKING VOLTAGE, or	No such high voltage	N/A
	– a d.c. test voltage equal to peak value of a.c. test voltage with an r.m.s. value equal to 1.06 times PEAK WORKING VOLTAGE, and	No such high voltage	N/A
	– CLEARANCE path was partly or entirely through air or along the surface of an insulating material of material group I	No such high voltage	N/A
	Dielectric strength test conducted only across part(s) of the path that are through air when CLEARANCE path was also partly along surface of a non- group I material	No such high voltage	N/A
8.9.1.14	Minimum CREEPAGE DISTANCES for two MEANS OF OPERATOR PROTECTION obtained by doubling values in Table 16 for one MEANS OF OPERATOR PROTECTION	Insulation is considered and evaluated as MOPP	N/A
8.9.1.15	CREEPAGE DISTANCES and AIR CLEARANCES for DEFIBRILLATION-PROOF APPLIED PARTS are 4 mm or more to meet 8.5.5.1	No such AP	N/A
8.9.2	a) Short circuiting of each single one of CREEPAGE DISTANCES and CLEARANCES in turn did not result in a HAZARDOUS SITUATION for insulation in MAINS PART between parts of opposite polarity, therefore, min CREEPAGE and CLEARANCES not applied..... :	No mains part	N/A
	b) Contribution to CREEPAGE DISTANCES of grooves or air gaps less than 1 mm wide limited to widths		P
	c) Relative positioning of CLEARANCE providing a MEANS OF PROTECTION is such that the relevant parts are rigid and located by molding, or there is no reduction of a distance below specified value by deformation or movement of parts		P
	Normal or likely limited movements of relevant parts taken into consideration when calculating minimum AIR CLEARANCE		P
8.9.3	Spaces filled by insulating compound		
8.9.3.1	Only solid insulation requirements applied where distances between conductive parts filled with insulating compound were such that CLEARANCES and CREEPAGE DISTANCES don't exist	No insulating compound filled	N/A
	Thermal cycling, humidity preconditioning, and dielectric strength tests in 8.9.3.2 and 8.9.3.4 or 8.9.3.3 and 8.9.3.4 conducted	No insulating compound filled	N/A

IEC 60601-1			
Clause	Requirement + Test	Result - Remark	Verdict
8.9.3.2	For insulating compound forming solid insulation between conductive parts, a single sample subjected to thermal cycling PROCEDURE of 8.9.3.4 followed by humidity preconditioning per 5.7 (for 48 hours), followed by dielectric strength test (clause 8.8.3), test voltage multiplied by 1.6	No insulating compound filled	N/A
	Cracks or voids in insulating compound affecting homogeneity of material didn't occur	No insulating compound filled	N/A
8.9.3.3	Where insulating compound forms a cemented joint with other insulating parts, three samples tested for reliability of joint	No insulating compound filled	N/A
	A winding of solvent-based enamelled wire replaced for the test by a metal foil or by a few turns of bare wire placed close to cemented joint, and three samples tested as follows:	No insulating compound filled	N/A
	– One sample subjected to thermal cycling PROCEDURE of 8.9.3.4, and immediately after the last period at highest temperature during thermal cycling, it was subjected to dielectric strength test of 8.8.3 except at 1.6 times the test voltage	No insulating compound filled	N/A
	– The other two samples subjected to humidity preconditioning of 5.7, except for 48 hours only followed by a dielectric strength test of 8.8.3 at 1.6 times the test voltage	No insulating compound filled	N/A
8.9.3.4	One sample containing the cemented joint subjected to a sequence of temperature cycling tests for 10 times	No insulating compound filled	N/A
8.10	Components and wiring		
8.10.1	Components of ME EQUIPMENT likely to result in an unacceptable RISK by their movements mounted securely as indicated in RISK MANAGEMENT FILE	RMF check is not included in this evaluation	N/E
8.10.2	Conductors and connectors of ME EQUIPMENT adequately secured or insulated to prevent accidental detachment in a HAZARDOUS SITUATION	RMF check is not included in this evaluation	N/E
	Conductors and connectors of ME EQUIPMENT when breaking free at their joint are not capable of touching circuit points resulting in a HAZARDOUS SITUATION as indicated in RISK MANAGEMENT FILE		P
	Breaking free of one means of mechanical restraint considered a SINGLE FAULT CONDITION		P
	Stranded conductors are not solder-coated when secured by clamping means to prevent HAZARDOUS SITUATIONS due to poor contact		P

IEC 60601-1			
Clause	Requirement + Test	Result - Remark	Verdict
8.10.3	Flexible cords detachable without a TOOL used to interconnect different parts of ME EQUIPMENT provided with means for connection to comply with requirements for metal ACCESSIBLE PARTS of 8.4 when a connection is loosened or broken as shown by measurement or using test finger	No flexible cords	N/A
8.10.4	Cord-connected HAND-HELD parts and cord-connected foot-operated control devices		
8.10.4.1	Control devices of ME EQUIPMENT and their connection cords contain only conductors and components operating at 42.4 V peak a.c., max, or 60 V d.c. in circuits isolated from MAINS PART by two MEANS OF PROTECTION	No cord-connected hand-held part / foot-operated control device	N/A
	d.c. limit of 60 V applied to d.c. with no more than 10 % peak-to-peak ripple	No cord-connected hand-held part / foot-operated control device	N/A
	42.4 V peak limit applied when ripple exceeded 10 % peak-to-peak limit	No cord-connected hand-held part / foot-operated control device	N/A
8.10.4.2	Connection and anchorage of a flexible cord to a HAND-HELD or foot-operated control device of ME EQUIPMENT at both ends of cable to control device complied with 8.11.3 when breaking free or shorting between conductors could result in a HAZARDOUS SITUATION	No cord-connected hand-held part / foot-operated control device	N/A
	This requirement applied to other HAND-HELD parts when disturbance or breaking of one or more of connections could result in a HAZARDOUS SITUATION	No cord-connected hand-held part / foot-operated control device	N/A
8.10.5	Mechanical protection of wiring		
	a) Internal cables and wiring adequately protected against contact with a moving part or from friction at sharp corners and edges where damage to insulation could result in a HAZARDOUS SITUATION	RMF check is not included in this evaluation	N/E
	b) Wiring, cord forms, or components are not likely to be damaged during assembly or during opening or closing of ACCESS COVERS where such damage could result in a HAZARDOUS SITUATION as shown by manual tests and RISK MANAGEMENT FILE		P
8.10.6	Guiding rollers of insulated conductors prevent bending of movable insulated conductors around a radius of less than five times the outer diameter of the lead concerned in NORMAL USE	No such part	N/A

IEC 60601-1			
Clause	Requirement + Test	Result - Remark	Verdict
8.10.7	a) Insulating sleeve that can only be removed by breaking or cutting, or secured at both ends, is used on internal wiring of when needed	No such part	N/A
	b) Sheath of a flexible cord not used as a MEANS OF PROTECTION inside ME EQUIPMENT when it is subject to mechanical or thermal stresses beyond its RATED characteristics	No such part	N/A
	c) Insulated conductors subject to temperatures > 70 °C in NORMAL USE provided with insulation of heat-resistant material when compliance is likely to be impaired due to deterioration of insulation	No such part	N/A
8.11	MAINS PARTS, components and layout		
8.11.1	a) ME EQUIPMENT provided with means of electrically isolating its circuits from SUPPLY MAINS simultaneously on all poles.....	No mains	N/A
	PERMANENTLY INSTALLED ME EQUIPMENT connected to a poly-phase SUPPLY MAINS equipped with a device not interrupting neutral conductor, provided local installation conditions prevent voltage on neutral conductor from exceeding limits in 8.4.2 c)	No mains	N/A
	b) Means of isolation incorporated in ME EQUIPMENT, and external means described in technical description	No mains	N/A
	c) A SUPPLY MAINS switch used to comply with 8.11.1 a) complies with CREEPAGE and CLEARANCES in IEC 61058-1 for a MAINS TRANSIENT VOLTAGE of 4 Kv.....	No mains	N/A
	d) A SUPPLY MAINS switch not incorporated in a POWER SUPPLY CORD or external flexible lead	No mains	N/A
	e) Direction of movement of actuator of a SUPPLY MAINS switch used to comply with 8.11.1 a) complies with IEC 60447	No mains	N/A
	f) A suitable plug device such as an APPLIANCE COUPLER or a flexible cord with a MAINS PLUG used in non-PERMANENTLY INSTALLED ME EQUIPMENT to isolate it from SUPPLY MAINS considered to comply with 8.11.1 a)	No mains	N/A
	g) A fuse or a semiconductor device not used as an isolating means	No mains	N/A
	h) ME EQUIPMENT not provided with a device causing disconnection of ME EQUIPMENT from SUPPLY MAINS by producing a short circuit resulting in operation of an overcurrent protection device	No mains	N/A

IEC 60601-1			
Clause	Requirement + Test	Result - Remark	Verdict
	i) Parts within ENCLOSURE of ME EQUIPMENT with a circuit > 42.4 V peak a.c. or 60 V d.c. that cannot be disconnected from its supply by an external switch or a plug device accessible at all times is protected against touch even after opening ENCLOSURE by an additional covering	No mains	N/A
	A clear warning notice is marked on outside of ME EQUIPMENT to indicate it exceeds allowable touch voltage (symbol 10 of Table D.1 is insufficient)	No mains	N/A
	For a part that could not be disconnected from supply by an external switch or a plug device accessible at all times, the required cover or warning notice complied with this clause	No mains	N/A
	Standard test finger of Fig 6 applied	No mains	N/A
8.11.2	MULTIPLE SOCKET-OUTLETS integral with ME EQUIPMENT complied with 16.2 d), second dash; and 16.9.2	No such part	N/A
8.11.3	POWER SUPPLY CORDS		
8.11.3.1	MAINS PLUG not fitted with more than one POWER SUPPLY CORD	No power supply cords	N/A
8.11.3.2	POWER SUPPLY CORDS are no less robust than ordinary tough rubber sheathed flexible cord (IEC 60245-1:2003, Annex A, designation 53) or ordinary polyvinyl chloride sheathed flexible cord (IEC 60227-1:1993, Annex A, design. 53).. :	No power supply cords	N/A
	Only polyvinyl chloride insulated POWER SUPPLY CORD with appropriate temperature rating used for ME EQUIPMENT having external metal parts with a temperature > 75 °C touchable by the cord in NORMAL USE	No power supply cords	N/A
8.11.3.3	NOMINAL cross-sectional area of conductors of POWER SUPPLY CORDS of ME EQUIPMENT is not less than in Table 17 (mm ² Cu)..... :	No power supply cords	N/A
8.11.3.4	APPLIANCE COUPLERS complying with IEC 60320-1 are considered to comply with 8.11.3.5 and 8.11.3.6..... :	No power supply cords	N/A
8.11.3.5	Cord anchorage (for APPLIANCE COUPLERS not complying with IEC 60320-1)		
	a) Conductors of POWER SUPPLY CORD provided with strain relieve and insulation protected from abrasion at point of entry to ME EQUIPMENT or a MAINS CONNECTOR by a cord anchorage	No power supply cords	N/A
	b) Cord anchorage of POWER SUPPLY CORD is made of and arranged as follows when a total insulation failure of POWER SUPPLY CORD caused conductive non-PROTECTIVELY EARTHED ACCESSIBLE PARTS to exceed limits of 8.4:	No power supply cords	N/A

IEC 60601-1			
Clause	Requirement + Test	Result - Remark	Verdict
	– insulating material, or	No power supply cords	N/A
	– metal, insulated from conductive ACCESSIBLE PARTS non-PROTECTIVELY EARTHED by a MEANS OF PROTECTION, or	No power supply cords	N/A
	– metal provided with an insulating lining affixed to cord anchorage, except when it is a flexible bushing forming part of the cord guard in 8.11.3.6, and complying with the requirements for one MEANS OF PROTECTION	No power supply cords	N/A
	c) Cord anchorage prevents cord from being clamped by a screw bearing directly on cord insulation	No power supply cords	N/A
	d) Screws to be operated when replacing POWER SUPPLY CORD do not serve to secure any components other than parts of cord anchorage	No power supply cords	N/A
	e) Conductors of POWER SUPPLY CORD arranged to prevent PROTECTIVE EARTH CONDUCTOR against strain as long as phase conductors are in contact with their terminals when cord anchorage fails	No power supply cords	N/A
	f) Cord anchorage prevents POWER SUPPLY CORD from being pushed into ME EQUIPMENT OR MAINS CONNECTOR	No power supply cords	N/A
	Conductors of POWER SUPPLY CORD supplied by MANUFACTURER disconnected from terminals or from MAINS CONNECTOR and cord subjected 25 times to a pull applied with no jerks, each time for 1 s, on sheath of the value in Table 18 :	No power supply cords	N/A
	Cord subjected to a torque in Table 18 for 1 min immediately after pull tests	No power supply cords	N/A
	Cord anchorage did not allow cord sheath to be longitudinally displaced by more than 2 mm or conductor ends to move over a distance of more than 1 mm from their connected position	No power supply cords	N/A
	CREEPAGE and CLEARANCES not reduced below limits in 8.9	No power supply cords	N/A
	It was not possible to push the cord into ME EQUIPMENT OR MAINS CONNECTOR to an extent the cord or internal parts would be damaged	No power supply cords	N/A
8.11.3.6	POWER SUPPLY CORDS other than for STATIONARY ME EQUIPMENT protected against excessive bending at inlet opening of equipment or of MAINS CONNECTOR by means of an insulating cord guard or by means of an appropriately shaped opening	No power supply cords	N/A
	Cord guard complied with test of IEC 60335-1:2001, Clause 25.14, or	No power supply cords	N/A

IEC 60601-1			
Clause	Requirement + Test	Result - Remark	Verdict
	ME EQUIPMENT placed such that axis of cord guard projected at an angle of 45° with cord free from stress, and a mass equal 10 x D ² gram attached to the free end of cord (g) :	No power supply cords	N/A
	Cord guard of temperature-sensitive material tested at 23 °C ± 2 °C, and flat cords bent in the plane of least resistance	No power supply cords	N/A
	Curvature of the cord radius, immediately after mass attached, was not less than 1.5 x D..... :	No power supply cords	N/A
8.11.4	MAINS TERMINAL DEVICES		
8.11.4.1	PERMANENTLY INSTALLED and ME EQUIPMENT with non-DETACHABLE POWER SUPPLY CORD replaceable by SERVICE PERSONNEL provided with MAINS TERMINAL DEVICES ensuring reliable connection	No mains terminal device	N/A
	Terminals alone are not used to keep conductors in position, except when barriers are provided such that CREEPAGE and CLEARANCES cannot be reduced below 8.9 if any conductor breaks away	No mains terminal device	N/A
	Terminals of components other than terminal blocks complying with requirements of this Clause and marked according to 7.3.7 used as terminals intended for external conductors	No mains terminal device	N/A
	Screws and nuts clamping external conductors do not serve to secure any other component, except they also clamp internal conductors when unlikely to be displaced when fitting the supply conductors	No mains terminal device	N/A
8.11.4.2	Arrangement of MAINS TERMINAL DEVICES		
	a) Terminals provided for connection of external cords or POWER SUPPLY CORDS together with PROTECTIVE EARTH TERMINAL grouped to provide convenient means of connection	No mains terminal device	N/A
	b) PROTECTIVE EARTH CONDUCTOR connections complied with 8.6	No mains terminal device	N/A
	c) Marking of MAINS TERMINAL DEVICES complied with 7.3	No mains terminal device	N/A
	d) MAINS TERMINAL DEVICES not accessible without use of a TOOL	No mains terminal device	N/A
	e) A MEANS OF PROTECTION are not short circuited when one end of a flexible conductor with NOMINAL cross-sectional area is stripped 8 mm and a single free wire is bent in each possible direction	No mains terminal device	N/A

IEC 60601-1			
Clause	Requirement + Test	Result - Remark	Verdict
8.11.4.3	Internal wiring not subjected to stress and CREEPAGE and CLEARANCES not reduced below 8.9 after fastening and loosening a conductor of largest cross-sectional area 10 times	No mains terminal device	N/A
8.11.4.4	Terminals with clamping means for a rewirable flexible cord did not require special preparation of conductors and conductors were not damaged and did not slip out when clamping means tightened as verified by test of 8.11.3.4	No mains terminal device	N/A
8.11.4.5	Adequate space provided inside ME EQUIPMENT designed for FIXED wiring or a re-wirable POWER SUPPLY CORD to allow for connection of conductors, and covers fitted without damage to conductors or their insulation	No mains terminal device	N/A
	Correct connection and positioning of conductors before ACCESS COVER was fitted verified by an installation test	No mains terminal device	N/A
8.11.5	Mains fuses and OVER-CURRENT RELEASES		
	A fuse or OVER-CURRENT RELEASE provided in each supply lead for CLASS I and CLASS II ME EQUIPMENT with a functional earth connection per clause 8.6.9, and in at least one supply lead for other single-phase CLASS II ME EQUIPMENT.... :	No mains	N/A
	– neutral conductor not fused for PERMANENTLY INSTALLED ME EQUIPMENT	No mains	N/A
	– fuses or OVER-CURRENT RELEASES omitted due to provision of two MEANS OF PROTECTION between all parts of opposite polarity within MAINS PART, and between all parts of MAINS PART and earth, and such provisions continued within all components	No mains	N/A
	Effect of short-circuit fault conditions in other circuits taken into consideration before eliminating fuses or OVER-CURRENT RELEASES	No mains	N/A
	Protective devices have adequate breaking capacity to interrupt the maximum fault current including the available short-circuit :	No mains	N/A
	A fuse or OVER-CURRENT RELEASE not provided in a PROTECTIVE EARTH CONDUCTOR	No mains	N/A
	Fuses complying with IEC 60127 have high breaking capacity (1 500 A) and prospective short-circuit current > 35 A or 10 times current rating of the fuse, whichever is greater	No mains	N/A
	Justification for omission of fuses or OVER-CURRENT RELEASES is in RISK MANAGEMENT FILE	No mains	N/A
8.11.6	Internal wiring of the MAINS PART		

IEC 60601-1			
Clause	Requirement + Test	Result - Remark	Verdict
	a) Cross-sectional area of internal wiring in a MAINS PART between MAINS TERMINAL DEVICE and protective devices is not less than minimum required for POWER SUPPLY CORD as in clause 8.11.3.3 (mm ² Cu)..... :	No mains	N/A
	b) Cross-sectional area of other wiring in MAINS PART and sizes of tracks on printed wiring circuits sufficient to prevent fire in case of fault currents..... :	No mains	N/A
	When necessary, ME EQUIPMENT connected to a SUPPLY MAINS with max available short-circuit fault, and subsequent simulation of a fault in a single insulation in MAINS PART did not result in any of the HAZARDOUS SITUATIONS in 13.1.2	No mains	N/A
9	PROTECTION AGAINST MECHANICAL HAZARDS OF ME EQUIPMENT AND ME SYSTEMS		
9.1	ME EQUIPMENT complies with Clause 4 for design and manufacture, and mechanical strength (15.3)		P
9.2	HAZARDS associated with moving parts		
9.2.1	When ME EQUIPMENT with moving parts PROPERLY INSTALLED, used per ACCOMPANYING DOCUMENTS or under foreseeable misuse, RISKS associated with moving parts reduced to an acceptable level.....:	No moving part	N/A
	RISK from contact with moving parts reduced to an acceptable level using protective measures, (access, function, shape of parts, energy, speed of motion, and benefits to PATIENT considered)	No moving part	N/A
	RESIDUAL RISK associated with moving parts considered acceptable when exposure was needed for ME EQUIPMENT to perform its function	No moving part	N/A
	Warnings marked on ME EQUIPMENT or included in instructions for use when HAZARDS persisted after implementing all reasonable protective measures.....:	No moving part	N/A
9.2.2	TRAPPING ZONE		
9.2.2.1	ME EQUIPMENT with a TRAPPING ZONE complied with one or more of the following as feasible:	No trapping zone	N/A
	– Gaps in Clause 9.2.2.2, or	No trapping zone	N/A
	– Safe distances in Clause 9.2.2.3, or	No trapping zone	N/A
	– GUARDS and protective measures in 9.2.2.4, or	No trapping zone	N/A
	– Continuous activation in Clause 9.2.2.5	No trapping zone	N/A

IEC 60601-1			
Clause	Requirement + Test	Result - Remark	Verdict
	Control of relevant motion complied with 9.2.2.6 when implementation of above protective measures were inconsistent with INTENDED USE of ME EQUIPMENT or ME SYSTEM	No trapping zone	N/A
9.2.2.2	A TRAPPING ZONE considered not to present a MECHANICAL HAZARD when gaps of TRAPPING ZONE complied with dimensions per Table 20 ..:	No trapping zone	N/A
9.2.2.3	A TRAPPING ZONE considered not to present a MECHANICAL HAZARD when distances separating OPERATOR, PATIENT, and others from TRAPPING ZONES exceeded values in ISO 13852	No trapping zone	N/A
	Distances measured from expected positions of OPERATOR, PATIENT, and others near EQUIPMENT in NORMAL USE or under foreseeable misuse	No trapping zone	N/A
9.2.2.4	GUARDS and protective measures		
9.2.2.4.1	A TRAPPING ZONE considered not to present a MECHANICAL HAZARD when GUARDS and protective measures were of robust construction, not easy to bypass or render non-operational, and did not introduce additional unacceptable RISK based on results of applicable tests in 15.3 for ENCLOSURES.....:	No trapping zone	N/A
9.2.2.4.2	FIXED GUARDS held in place by systems that cannot be dismantled without a TOOL	No trapping zone	N/A
9.2.2.4.3	Movable GUARDS that can be opened without a TOOL remained attached when GUARD was open	No trapping zone	N/A
	– they are associated with an interlock preventing relevant moving parts from starting to move while TRAPPING ZONE is accessible, and stops movement when the GUARD is opened,	No trapping zone	N/A
	– absence or failure of one of their components prevents starting, and stops moving parts	No trapping zone	N/A
	Movable GUARDS complied with all applicable tests as confirmed by review of RISK MANAGEMENT FILE	No trapping zone	N/A
9.2.2.4.4	Protective measures provided in control system prevented moving parts from starting to move while in reach of persons	No trapping zone	N/A
	– protective measures prevented TRAPPING ZONE from reach, or, when it was reached, system movement stopped once ME EQUIPMENT started to move, and in the latter case, no HAZARD or damage resulted	No trapping zone	N/A

IEC 60601-1			
Clause	Requirement + Test	Result - Remark	Verdict
	– when protective measure was in a SINGLE FAULT CONDITION, and an unacceptable RISK could arise, one or more emergency stopping device(s) provided	No trapping zone	N/A
	RISK MANAGEMENT FILE reviewed and all conditions confirmed	No trapping zone	N/A
9.2.2.5	Continuous activation		
	TRAPPING ZONE not considered to present a MECHANICAL HAZARD where impractical to make TRAPPING ZONE inaccessible when:	No trapping zone	N/A
	a) movement was in OPERATOR'S field of view	No trapping zone	N/A
	b) movement of ME EQUIPMENT or its parts was possible only by continuous activation of control by OPERATOR as long as OPERATOR response to deactivate device relied upon to prevent HARM	No trapping zone	N/A
	Manually operated movements complied with this clause since mass and velocity allowed adequate control of positioning without causing an unacceptable RISK	No trapping zone	N/A
	c) when in a SINGLE FAULT CONDITION of continuous activation system an unacceptable RISK could arise, one or more emergency stopping device(s) provided in ME EQUIPMENT ...:	No trapping zone	N/A
9.2.2.6	Speed of movement(s) positioning parts of ME EQUIPMENT or PATIENT, when contact with ME EQUIPMENT could result in a HAZARDOUS SITUATION, limited to allow OPERATOR control of positioning without resulting in an unacceptable RISK	No trapping zone	N/A
	Over travel (stopping distance) of such movement occurring after operation of a control to stop movement, did not result in an unacceptable RISK	No trapping zone	N/A
9.2.3	Other HAZARDS associated with moving parts		
9.2.3.1	Controls positioned, recessed, or protected by other means and could not be accidentally actuated to result in unacceptable RISK, except when ergonomic considerations for a PATIENT with special needs require otherwise	No moving part	N/A
9.2.3.2	RISK due to over travel (past range limits) of ME EQUIPMENT parts reduced to an acceptable level, and stops or other means with mechanical strength to withstand intended loading in NORMAL USE and foreseeable misuse provided limiting measure in NORMAL and SINGLE FAULT CONDITION	No moving part	N/A
9.2.4	Emergency stopping devices		

IEC 60601-1			
Clause	Requirement + Test	Result - Remark	Verdict
	Where necessary to have one or more emergency stopping device(s), emergency stopping device complied with all the following, except for actuating switch capable of interrupting all power	No moving part	N/A
	a) Emergency stopping device reduced RISK to an acceptable level	No moving part	N/A
	b) Proximity and response of OPERATOR to actuate emergency stopping device could be relied upon to prevent HARM	No moving part	N/A
	c) Emergency stopping device actuator was readily accessible to OPERATOR	No moving part	N/A
	d) Emergency stopping device(s) are not part of normal operation of ME EQUIPMENT	No moving part	N/A
	e) Emergency switching operation or stopping means neither introduced further HAZARD nor interfered with operation necessary to remove original HAZARD	No moving part	N/A
	f) Emergency stopping device was able to break full load of relevant circuit, including possible stalled motor currents and the like	No moving part	N/A
	g) Means for stopping of movements operate as a result of one single action	No moving part	N/A
	h) Emergency stopping device provided with an actuator in red and easily distinguishable and identifiable from other controls	No moving part	N/A
	i) An actuator interrupting/opening mechanical movements marked on or immediately adjacent to face of actuator with symbol 18 of Table D.1 (symbol IEC 60417-5638, DB:2002-10) or "STOP"	No moving part	N/A
	j) Emergency stopping device, once actuated, maintained ME EQUIPMENT in disabled condition until a deliberate action, different from that used to actuate it, was performed	No moving part	N/A
	k) Emergency stopping device is suitable for its application	No moving part	N/A
9.2.5	Means provided to permit quick and safe release of PATIENT in event of breakdown of ME EQUIPMENT or failure of power supply, activation of a protective measure, or emergency stopping, and	No such means	N/A
	– Uncontrolled or unintended movement of ME EQUIPMENT that could result in an unacceptable RISK prevented	No such means	N/A
	– Situations where PATIENT is subjected to unacceptable RISKS due to proximity of moving parts, removal of normal exit routes, or other HAZARDS prevented	No such means	N/A

IEC 60601-1			
Clause	Requirement + Test	Result - Remark	Verdict
	– Measures provided to reduce RISK to an acceptable level when after removal of counterbalanced parts, other parts of ME EQUIPMENT can move in a hazardous way	No such means	N/A
9.3	Rough surfaces, sharp corners and edges of ME EQUIPMENT that could result in an unacceptable RISK avoided or covered	RMF check is not included in this evaluation	N/E
9.4	Instability HAZARDS		
9.4.1	ME EQUIPMENT, other than FIXED and hand-held, for placement on a surface did not overbalance (tip over) or move unexpectedly, to the degree that it could present an unacceptable RISK to PATIENT, or OPERATOR as tested in 9.4.2 to 9.4.4	Fixed equipment	N/A
9.4.2	Instability – overbalance		
9.4.2.1	ME EQUIPMENT or its parts did not overbalance when prepared per ACCOMPANYING DOCUMENTS, or when not specified, as in 9.4.2.2, and placed on a 10° inclined plane from horizontal consisting of a hard and flat surface (e.g., concrete floor covered with 2 to 4 mm thick vinyl material)	Fixed equipment	N/A
9.4.2.2	Instability excluding transport		
	ME EQUIPMENT or its parts prepared based on a) to g), inclusive, did not overbalance when placed in different positions of NORMAL USE, except transport positions, on a 5° inclined plane from horizontal (hard and flat surface)	Fixed equipment	N/A
	A warning provided, stating “Transport only under conditions described in instructions for use or marked on ME EQUIPMENT with an indication of RESIDUAL RISK if ME EQUIPMENT or its parts overbalances” when overbalance occurred during 10° inclined plane test	Fixed equipment	N/A
9.4.2.3	Instability from horizontal and vertical forces		
	a) ME EQUIPMENT with a mass of 25 kg or more, other than FIXED ME EQUIPMENT for use on floor, did not overbalance due to pushing or resting	Fixed equipment	N/A
	Surfaces of ME EQUIPMENT where a RISK of overbalancing exists from pushing, leaning, resting etc., permanently marked with a CLEARLY LEGIBLE warning of the RISK (e.g., safety sign 5 of Table D.2, safety sign ISO 7010-P017)	Fixed equipment	N/A

IEC 60601-1			
Clause	Requirement + Test	Result - Remark	Verdict
	ME EQUIPMENT did not overbalance when placed on a horizontal plane, and a force of 25% of its weight, but not more than 220 N, applied in different directions, except a direction with an upward component	Fixed equipment	N/A
	b) ME EQUIPMENT, other than FIXED ME EQUIPMENT, for use on the floor or on a table, did not overbalance due to sitting or stepping, except when a legible warning of this RISK provided on ME EQUIPMENT (e.g., safety signs 6 and 7 of Table D.2, safety signs ISO 7010-P018, or ISO 7010-P019 as appropriate)	Fixed equipment	N/A
	ME EQUIPMENT did not overbalance when placed on a horizontal plane, and a constant force of 800 N applied at the point of maximum moment to working surfaces, offering an foothold or sitting surface of a min 20 x 20 cm area, and at a height \leq 1 m from the floor	Fixed equipment	N/A
9.4.2.4	Castors and wheels		
9.4.2.4.1	Means used for transportation of MOBILE ME EQUIPMENT (e.g., castors or wheels) did not result in an unacceptable RISK when MOBILE ME EQUIPMENT moved or parked in NORMAL USE	Fixed equipment	N/A
9.4.2.4.2	Force required to move MOBILE ME EQUIPMENT along a hard and flat horizontal surface did not exceed 200 N applied at a height of 1 m above floor or highest point on ME EQUIPMENT when < 1 m high, except when instructions indicated more than one person needed (N).....:	Fixed equipment	N/A
9.4.2.4.3	MOBILE ME EQUIPMENT exceeding 45 kg configured with a SAFE WORKING LOAD, moved 10 times in forward direction over a solid vertical plane obstruction with wheels impacting the obstruction at a speed of 0.4 m/s \pm 0.1 m/s for manual or with max speed for motor driven MOBILE ME EQUIPMENT	Fixed equipment	N/A
	ME EQUIPMENT went up the obstruction without overbalancing or any other unacceptable RISK as determined by examination of RISK MANAGEMENT FILE, ME EQUIPMENT and its parts.....:	Fixed equipment	N/A
	There was no reduction of CREEPAGE and CLEARANCES below 8.9, no access to parts exceeding limits in 8.4, and no access to moving parts capable of causing HARM, and	Fixed equipment	N/A
	– Assessment criteria in Clause 9 and 11.6 used	Fixed equipment	N/A
	– Dielectric strength test of 8.8.3 conducted to evaluate integrity of solid SUPPLEMENTARY or REINFORCED INSULATION	Fixed equipment	N/A

IEC 60601-1			
Clause	Requirement + Test	Result - Remark	Verdict
	– CREEPAGE DISTANCES and AIR CLEARANCES measured compared favourably with min distances in clause 8.9	Fixed equipment	N/A
	Small chips not adversely affecting protection against electric shock or moisture, disregarded	Fixed equipment	N/A
9.4.3	Instability from unwanted lateral movement (including sliding)		
9.4.3.1	a) Brakes of power-driven MOBILE ME EQUIPMENT normally activated and could only be released by continuous actuation of a control	Fixed equipment	N/A
	b) MOBILE ME EQUIPMENT provided with locking means to prevent unwanted movements of ME EQUIPMENT or its parts in transport position	Fixed equipment	N/A
	c) No unacceptable RISK due to unwanted lateral movement resulted when MOBILE ME EQUIPMENT placed in its transport position or worst case NORMAL USE position with SAFE WORKING LOAD, and locking device activated, on a 10° inclined hard flat surface with castors in the worst-case position	Fixed equipment	N/A
	Following initial elastic movement, creepage, and pivoting of castors, no further movement of MOBILE ME EQUIPMENT > 50 mm (in relation to inclined plane) occurred (mm).....:	Fixed equipment	N/A
	RISK due to any initial movement assessed taking into consideration NORMAL USE of ME EQUIPMENT	Fixed equipment	N/A
9.4.3.2	Instability excluding transport		
	a) Further movement of ME EQUIPMENT (after initial elastic movement) was less than 50 mm when MOBILE ME EQUIPMENT with a SAFE WORKING LOAD positioned on a 5° inclined hard flat surface with wheel locked or braking system activated (mm).....:	Fixed equipment	N/A
	RISK due to initial movements assessed taking into consideration NORMAL USE of ME EQUIPMENT	Fixed equipment	N/A
	b) TRANSPORTABLE or STATIONARY ME EQUIPMENT for use on the floor and with a SAFE WORKING LOAD prepared as in 9.4.2.2 and placed on a horizontal plane with locking device activated and castors, when supplied, in their worst – case position	Fixed equipment	N/A

IEC 60601-1			
Clause	Requirement + Test	Result - Remark	Verdict
	Further movement of ME EQUIPMENT (after initial elastic movement), was no more than 50 mm when a force of 25 % of weight of unit, but less than 220 N, applied in different directions, except a direction with an upwards component, at highest point of ME EQUIPMENT but ≤ 1.5 m from floor	Fixed equipment	N/A
	RISK due to initial movements assessed taking into consideration NORMAL USE of ME EQUIPMENT	Fixed equipment	N/A
9.4.4	Grips and other handling devices		
	a) ME EQUIPMENT other than PORTABLE EQUIPMENT or its part with a mass of over 20 kg requiring lifting in NORMAL USE or transport provided with suitable handling means, or ACCOMPANYING DOCUMENTS specify safe lifting method, except when handling is obvious and causing HAZARDS	Fixed equipment	N/A
	Handles, when supplied, suitably placed to enable ME EQUIPMENT or its part to be carried by two or more persons and by examination of EQUIPMENT, its part, or ACCOMPANYING DOCUMENTS	Fixed equipment	N/A
	b) PORTABLE ME EQUIPMENT with a mass > 20 kg provided with one or more carrying-handles suitably placed to enable carrying by two or more persons as confirmed by actual carrying	Fixed equipment	N/A
	c) Carrying handles and grips and their means of attachment withstood loading test	Fixed equipment	N/A
9.5	Expelled parts HAZARD		
9.5.1	Suitability of means of protecting against unacceptable RISK of expelled parts determined by assessment and examination of RISK MANAGEMENT FILE.....	No such part	N/A
9.5.2	Cathode ray tube(s) complied with IEC 60065:2001, Clause 18, or IEC 61965	No such part	N/A
9.6	Acoustic energy (including infra- and ultrasound) and vibration		
9.6.1	Human exposure to acoustic energy and vibration from ME EQUIPMENT doesn't result in unacceptable RISK as confirmed in RISK MANAGEMENT FILE including audibility of auditory alarm signals, PATIENT sensitivity, and tests of 9.6.2 and 9.6.3	No acoustic energy / vibration	N/A
9.6.2	Acoustic energy		
9.6.2.1	PATIENT, OPERATOR, and other persons are not exposed to acoustic energy from ME EQUIPMENT in NORMAL USE, except for auditory alarm signals	No acoustic energy / vibration	N/A

IEC 60601-1			
Clause	Requirement + Test	Result - Remark	Verdict
	– 80 Dba for a cumulative exposure of 24 h over a 24 h period (Dba)	No acoustic energy / vibration	—
	- 83 Dba (when halving the cumulative exposure time) (Dba)	No acoustic energy / vibration	—
	– 140 Db un-weighted sound pressure level for impulsive or impact acoustic energy (Db).....	No acoustic energy / vibration	—
9.6.2.2	RISK MANAGEMENT FILE examined for RISKS associated with infrasound or ultrasound, when present, addressed in RISK MANAGEMENT PROCESS	RMF check is not included in this evaluation	N/E
9.6.3	Hand-transmitted vibration		
	Means provided, except for INTENDED USE vibrations, to protect PATIENT and OPERATOR when hand-transmitted frequency-weighted r.m.s. acceleration generated in NORMAL USE exceeds specified values measured at points of hand contact with PATIENT or OPERATOR	Not hand-held equipment	N/A
	– 2.5 m/s ² for a cumulative time of 8 h during a 24 h period (m/s ²)	Not hand-held equipment	N/A
	– Accelerations for different times, inversely proportional to square root of time (m/s ²).....	Not hand-held equipment	N/A
9.7	Pressure vessels and parts subject to pneumatic and hydraulic pressure		
9.7.1	Requirements of this clause applied to vessels and parts of ME EQUIPMENT subject to pressure resulting in rupture and unacceptable RISK	No pressure vessel	N/A
	Parts of a pneumatic or hydraulic system used as a support system, comply with 9.8	No pressure vessel	N/A
9.7.2	Pneumatic and hydraulic parts of ME EQUIPMENT or ACCESSORIES met following requirements based on examination of RISK MANAGEMENT FILE	No pressure vessel	N/A
	– No unacceptable RISK resulted from loss of pressure or loss of vacuum	No pressure vessel	N/A
	– No unacceptable RISK resulted from a fluid jet caused by leakage or a component failure	No pressure vessel	N/A
	– Elements of ME EQUIPMENT or an ACCESSORY, especially pipes and hoses leading to an unacceptable RISK protected against harmful external effects	No pressure vessel	N/A
	– Reservoirs and similar vessels leading to an unacceptable RISK are automatically depressurized when ME EQUIPMENT is isolated from its power supply	No pressure vessel	N/A

IEC 60601-1			
Clause	Requirement + Test	Result - Remark	Verdict
	Means provided for isolation, or local depressurizing reservoirs and similar vessels, and pressure indication when above not possible	No pressure vessel	N/A
	– All elements remaining under pressure after isolation of ME EQUIPMENT or an ACCESSORY from its power supply resulting in an unacceptable RISK provided with clearly identified exhaust devices, and a warning to depressurize these elements before setting or maintenance activity	No pressure vessel	N/A
9.7.3	Maximum pressure a part of ME EQUIPMENT can be subjected to in NORMAL and SINGLE FAULT CONDITIONS considered to be highest of following:	No pressure vessel	N/A
	a) RATED maximum supply pressure from an external source	No pressure vessel	N/A
	b) Pressure setting of a pressure-relief device provided as part of assembly	No pressure vessel	N/A
	c) Max pressure that can develop by a source of pressure that is part of assembly, unless pressure limited by a pressure-relief device	No pressure vessel	N/A
9.7.4	Max pressure in NORMAL and SINGLE FAULT CONDITIONS did not exceed MAXIMUM PERMISSIBLE WORKING PRESSURE for EQUIPMENT part, except as allowed in 9.7.7, confirmed by examination of ME EQUIPMENT and RISK MANAGEMENT FILE, and by functional tests	No pressure vessel	N/A
9.7.5	A pressure vessel withstood a HYDRAULIC TEST PRESSURE when pressure was > 50 kPa, and product of pressure and volume was more than 200 kPal	No pressure vessel	N/A
9.7.6	Pressure-control device regulating pressure in ME EQUIPMENT with pressure-relief device completed 100,000 cycles of operation under RATED load and prevented pressure from exceeding 90 % of setting of pressure-relief device in different conditions of NORMAL USE .:	No pressure control device	N/A
9.7.7	Pressure-relief device(s) used where MAXIMUM PERMISSIBLE WORKING PRESSURE could otherwise be exceeded met the following, as confirmed by MANUFACTURER'S data, ME EQUIPMENT, RISK MANAGEMENT FILE, and functional tests	No pressure relief device	N/A
	a) Connected as close as possible to pressure vessel or parts of system it is to protect	No pressure relief device	N/A
	b) Installed to be readily accessible for inspection, maintenance, and repair	No pressure relief device	N/A

IEC 60601-1			
Clause	Requirement + Test	Result - Remark	Verdict
	c) Could be adjusted or rendered inoperative without a TOOL	No pressure relief device	N/A
	d) With discharge opening located and directed as to not to release material towards any person	No pressure relief device	N/A
	e) With discharge opening located and directed as to not to deposit material on parts that could result in an unacceptable RISK	No pressure relief device	N/A
	f) Adequate discharge capacity provided to ensure that pressure will not exceed MAXIMUM PERMISSIBLE WORKING PRESSURE of system it is connected to by more than 10 % when failure occurs in control of supply pressure	No pressure relief device	N/A
	g) No shut-off valve provided between a pressure-relief device and parts it is to protect	No pressure relief device	N/A
	h) Min number of cycles of operation 100 000, except for one-time use devices (bursting disks)	No pressure relief device	N/A
9.8	HAZARDS associated with support systems		
9.8.1	ME EQUIPMENT parts designed to support loads or provide actuating forces when a mechanical fault could constitute an unacceptable RISK	No support system	N/A
	– Construction of support, suspension, or actuation system complied with Table 21 and TOTAL LOAD	No support system	N/A
	– Means of attachment of ACCESSORIES prevent possibility of incorrect attachment that could result in an unacceptable RISK	No support system	N/A
	– RISK ANALYSIS of support systems included HAZARDS from static, dynamic, vibration, impact and pressure loading, foundation and other movements, temperature, environmental, manufacture and service conditions	No support system	N/A
	– RISK ANALYSIS included effects of failures such as excessive deflection, plastic deformation, ductile/brittle fracture, fatigue fracture, instability (buckling), stress-assisted corrosion cracking, wear, material creep and deterioration, and residual stresses from manufacturing PROCESSES	No support system	N/A
	– Instructions on attachment of structures to a floor, wall, ceiling, included in ACCOMPANYING DOCUMENTS making adequate allowances for quality of materials used to make the connection and list the required materials	No support system	N/A

IEC 60601-1			
Clause	Requirement + Test	Result - Remark	Verdict
	Additional instructions provided on checking adequacy of surface of structure parts will be attached to	No support system	N/A
9.8.2	Support systems maintain structural integrity during EXPECTED SERVICE LIFE, and TENSILE SAFETY FACTORS are not less than in Table 21, except when an alternative method used to demonstrate structural integrity throughout EXPECTED SERVICE LIFE, or for a foot rest	No support system	N/A
	Compliance with 9.8.1 and 9.8.2 confirmed by examination of ME EQUIPMENT, RISK MANAGEMENT FILE, specifications and material processing...:	No support system	N/A
	When test results were part of information, testing consisted of application of a test load to support assembly equal to TOTAL LOAD times required TENSILE SAFETY FACTOR while support assembly under test was in equilibrium after 1 min, or not resulted in an unacceptable RISK...:	No support system	N/A
9.8.3	Strength of PATIENT or OPERATOR support or suspension systems		
9.8.3.1	ME EQUIPMENT parts supporting or immobilizing PATIENTS minimize RISK of physical injuries and accidental loosening of secured joints	No support system	N/A
	SAFE WORKING LOAD of ME EQUIPMENT or its parts supporting or suspending PATIENTS or OPERATORS is sum of mass of PATIENTS or mass of OPERATORS plus mass of ACCESSORIES supported by ME EQUIPMENT or its parts	No support system	N/A
	Supporting and suspending parts for adult human PATIENTS or OPERATORS designed for a PATIENT or OPERATOR with a min mass of 135 kg and ACCESSORIES with a min mass of 15 kg, unless stated by MANUFACTURER	No support system	N/A
	Maximum mass of PATIENT included in SAFE WORKING LOAD of ME EQUIPMENT or its parts supporting or suspending PATIENTS adapted when MANUFACTURER specified applications	No support system	N/A
	Max allowable PATIENT mass < 135 kg marked on ME EQUIPMENT and stated in ACCOMPANYING DOCUMENTS	No support system	N/A
	Max allowable PATIENT mass > 135 kg stated in ACCOMPANYING DOCUMENTS	No support system	N/A
	Examination of markings, ACCOMPANYING DOCUMENTS, and RISK MANAGEMENT FILE confirmed compliance	No support system	N/A
9.8.3.2	Part of SAFE WORKING LOAD representing mass of PATIENTS or OPERATORS is distributed on support/suspension surface representing human body as in Fig A.19	No support system	N/A

IEC 60601-1			
Clause	Requirement + Test	Result - Remark	Verdict
	Part of SAFE WORKING LOAD representing mass of ACCESSORIES deployed as in NORMAL USE and, when not defined, at worst case position permitted by configuration or ACCESSORIES attachment on support/suspension parts	No support system	N/A
	a) Entire mass of PATIENT or OPERATOR distributed over an area of 0.1 m ² on a foot rest temporarily supporting a standing PATIENT or OPERATOR	No support system	N/A
	Compliance confirmed by examination of ME EQUIPMENT, RISK MANAGEMENT FILE, specifications of materials and their processing, and tests	No support system	N/A
	PATIENT support/suspension system positioned horizontally in most disadvantageous position in NORMAL USE, and a mass 2 x 135 kg or twice intended person's load (the greater used), applied to foot rest over an area of 0.1 m ² for 1 min (Kg).....	No support system	N/A
	Damage or deflection resulting in an unacceptable RISK did not occur on foot rest and its secured joints	No support system	N/A
	b) Deflection of a support surface from PATIENT or OPERATOR loading on an area of support/suspension where a PATIENT or OPERATOR can sit did not result in an unacceptable RISK.....	No support system	N/A
	Compliance confirmed by examination of ME EQUIPMENT, RISK MANAGEMENT FILE, specifications of materials and their processing, and by a test	No support system	N/A
	PATIENT support/suspension system set in most unfavourable NORMAL USE position, and a mass of 60 % of part of SAFE WORKING LOAD simulating PATIENT or OPERATOR, or a min 80 kg, placed on support or suspension system with centre of load 60 mm from outer edge of support or suspension system for at least one minute (Kg)	No support system	N/A
	Deflection of support/suspension system resulting in an unacceptable RISK not occur	No support system	N/A
9.8.3.3	Dynamic forces that can be exerted on equipment parts supporting or suspending a PATIENT or OPERATOR in NORMAL USE did not result in an unacceptable RISK as confirmed by following test:	No support system	N/A

IEC 60601-1			
Clause	Requirement + Test	Result - Remark	Verdict
	PATIENT support/suspension system set in most unfavourable NORMAL USE position, and a mass equal to SAFE WORKING LOAD simulating PATIENT or OPERATOR dropped from 150 mm above seat area on an area of support/suspension a PATIENT or OPERATOR can sit..... :	No support system	N/A
9.8.4	Systems with MECHANICAL PROTECTIVE DEVICES		
9.8.4.1	a) A MECHANICAL PROTECTIVE DEVICE provided when a support system or its parts impaired by wear have a TENSILE SAFETY FACTOR \geq to values in Table 21, rows 5 and 6, but less than 3 and 4	No support system	N/A
	b) MECHANICAL PROTECTIVE complies with the requirements as follows:	No support system	N/A
	– Designed based on TOTAL LOAD, and includes effects of SAFE WORKING LOAD when applicable	No support system	N/A
	– Has TENSILE SAFETY FACTORS for all parts not less than Table 21, row 7	No support system	N/A
	– Activated before travel (movement) produced an unacceptable RISK	No support system	N/A
	– Takes into account Clauses 9.2.5 and 9.8.4.3	No support system	N/A
	Compliance confirmed by examination of ME EQUIPMENT, RISK MANAGEMENT FILE, specifications of materials and their processing	No support system	N/A
9.8.4.2	Activation of MECHANICAL PROTECTIVE DEVICE is made obvious to OPERATOR when ME EQUIPMENT can still be used after failure of suspension or actuation means and activation of a MECHANICAL PROTECTIVE DEVICE (e.g., a secondary cable)	No support system	N/A
	MECHANICAL PROTECTIVE DEVICE requires use of a TOOL to be reset or replaced	No support system	N/A
9.8.4.3	MECHANICAL PROTECTIVE DEVICE intended to function once		
	– Further use of ME EQUIPMENT not possible until replacement of MECHANICAL PROTECTIVE DEVICE	No support system	N/A
	– ACCOMPANYING DOCUMENTS instruct once MECHANICAL PROTECTIVE DEVICE is activated, SERVICE PERSONNEL shall be called, and MECHANICAL PROTECTIVE DEVICE must be replaced before ME EQUIPMENT can be used	No support system	N/A
	– ME EQUIPMENT permanently marked with safety sign 2 of Table D.2 (i.e., safety sign 7010-W001)	No support system	N/A

IEC 60601-1			
Clause	Requirement + Test	Result - Remark	Verdict
	– Marking is adjacent to MECHANICAL PROTECTIVE DEVICE or its location relative to MECHANICAL PROTECTIVE DEVICE is obvious to service personnel	No support system	N/A
	– Compliance confirmed by examination of ME EQUIPMENT, ACCOMPANYING DOCUMENTS, RISK MANAGEMENT FILE, specifications and processing of materials, and following test	No support system	N/A
	A chain, cable, band, spring, belt, jack screw nut, pneumatic or hydraulic hose, structural part or the like, employed to support a load, defeated by a convenient means causing maximum normal load to fall from most adverse position permitted by construction of ME EQUIPMENT	No support system	N/A
	Load included SAFE WORKING LOAD in 9.8.3.1 when system was capable of supporting a PATIENT or OPERATOR	No support system	N/A
	No evidence of damage to MECHANICAL PROTECTIVE DEVICE affecting its ability to perform its intended function	No support system	N/A
9.8.5	Systems without MECHANICAL PROTECTIVE DEVICES		
	Support system parts have TENSILE SAFETY FACTORS \geq to values in Table 21, rows 1 and 2, and are not impaired by wear	No support system	N/A
	Support system parts impaired by wear, however, they have TENSILE SAFETY FACTORS \geq to values in Table 21, rows 3 and 4	No support system	N/A
	Examination of ME EQUIPMENT and RISK MANAGEMENT FILE confirmed compliance	No support system	N/A
10	PROTECTION AGAINST UNWANTED AND EXCESSIVE RADIATION HAZARDS		
10.1	X-Radiation		
10.1.1	X-radiation dose-rate was $\leq 36 \text{ Pa/kg}$ ($5 \mu\text{Sv/h}$) (0.5 Mr/h) 5 cm from surface of ME EQUIPMENT including background radiation for ME EQUIPMENT not producing therapeutic/diagnostic X-radiation but producing ionizing radiation . :	No radiation	N/A
	Amount of radiation measured by means of an ionizing chamber radiation monitor with an effective area of 10 cm^2 or by other instruments producing equal results	No radiation	N/A
	ME EQUIPMENT operated as in NORMAL USE at most unfavourable RATED MAINS VOLTAGE and controls adjusted to emit maximum radiation	No radiation	N/A

IEC 60601-1			
Clause	Requirement + Test	Result - Remark	Verdict
	Internal pre-set controls not intended for adjustment during EXPECTED SERVICE LIFE of ME EQUIPMENT not taken into consideration	No radiation	N/A
10.1.2	RISK from unintended X-radiation from ME EQUIPMENT producing X-radiation for diagnostic and therapeutic purposes addressed in RISK MANAGEMENT PROCESS as indicated in RISK MANAGEMENT FILE (see IEC 60601-1-3 & 1.3) :	No radiation	N/A
10.2	RISK associated with alpha, beta, gamma, neutron, and other particle radiation, when applicable, addressed in RISK MANAGEMENT PROCESS as shown in RISK MANAGEMENT FILE :	No radiation	N/A
10.3	RISK associated with microwave radiation, when applicable, addressed in RISK MANAGEMENT PROCESS as indicated in RISK MANAGEMENT FILE	No radiation	N/A
10.4	Relevant requirements of IEC 60825-1:1993 applied to lasers, light emitting diodes (LEDs), and laser light barriers or similar products	No laser, LED indicator comply with 60825-1	P
10.5	RISK associated with visible electromagnetic radiation other than emitted by lasers and LEDs, when applicable, addressed in RISK MANAGEMENT PROCESS as indicated in RISK MANAGEMENT FILE	No radiation	N/A
10.6	RISK associated with infrared radiation other than emitted by lasers and LEDs, as applicable, addressed in RISK MANAGEMENT PROCESS as indicated in RISK MANAGEMENT FILE	No radiation	N/A
10.7	RISK associated with ultraviolet radiation other than emitted by lasers and LEDs, as applicable, addressed in RISK MANAGEMENT PROCESS as indicated in RISK MANAGEMENT FILE	No radiation	N/A

11	PROTECTION AGAINST EXCESSIVE TEMPERATURES AND OTHER HAZARDS		
11.1	Excessive temperatures in ME EQUIPMENT		
11.1.1	Temperatures on ME EQUIPMENT parts did not exceed values in Tables 22 and 23 operating in worst-case NORMAL USE at maximum rated ambient operating temperature T	See appended Table 11.1.1	P
	Surfaces of test corner did not exceed 90 °C		P
	THERMAL CUT-OUTS did not operate in NORMAL CONDITION	No such part	N/A
11.1.2	Temperature of APPLIED PARTS		

IEC 60601-1			
Clause	Requirement + Test	Result - Remark	Verdict
11.1.2.1	Temperatures, hot or cold surfaces, and when appropriate, clinical effects of APPLIED PARTS supplying heat to a PATIENT determined and documented in RISK MANAGEMENT FILE and instructions for use	No AP intended to supply heat	N/A
11.1.2.2	APPLIED PARTS not supplying heat to a PATIENT met Table 24 with max surface temperatures > 41 °C disclosed in instructions for use, and clinical effects regarding maturity of PATIENTS, body surface, surface pressure, medications taken, as shown in RISK MANAGEMENT FILE.....	See appended Table 11.1.2.2	P
	Surfaces of APPLIED PARTS cooled below ambient temperatures that can also result in HAZARD evaluated as part of RISK MANAGEMENT PROCESS	No such situation	N/A
11.1.3	Measurements not made when engineering judgment and rationale by MANUFACTURER indicated temperature limits could not exceed, as documented in RISK MANAGEMENT FILE	Measurement is performed	N/A
	Test corner not used where engineering judgment and rationale by MANUFACTURER indicated test corner will not impact measurements, as documented in RISK MANAGEMENT FILE	Test corner used	N/A
	Probability of occurrence and duration of contact for parts likely to be touched and for APPLIED PARTS documented in RISK MANAGEMENT FILE	RMF check is not included in this evaluation	N/E
11.1.4	GUARDS preventing contact with hot or cold accessible surfaces removable only with a TOOL	No such guards	N/A
11.2	Fire prevention		
11.2.1	ENCLOSURE has strength and rigidity necessary to prevent a fire caused by reasonably foreseeable misuse and met mechanical strength tests for ENCLOSURES in 15.3		P
11.2.2	Me equipment and me systems used in conjunction with OXYGEN RICH ENVIRONMENTS		
11.2.2.1	RISK of fire in an OXYGEN RICH ENVIRONMENT reduced by means limiting spread of fire under NORMAL or SINGLE FAULT CONDITIONS when source of ignition in contact with ignitable material ..	EUT is not intended to be used in conjunction with Oxygen rich environment	N/A
	Requirements of 13.1.1 applied to oxygen concentrations up to 25 % at one atmosphere or partial pressures up to 27.5 kPa for higher atmospheric pressures	EUT is not intended to be used in conjunction with Oxygen rich environment	N/A

IEC 60601-1			
Clause	Requirement + Test	Result - Remark	Verdict
	a) No sources of ignition discovered in an OXYGEN RICH ENVIRONMENT in NORMAL and SINGLE FAULT CONDITIONS under any of the following conditions..... :	EUT is not intended to be used in conjunction with Oxygen rich environment	N/A
	1) when temperature of material raised to its ignition temperature	EUT is not intended to be used in conjunction with Oxygen rich environment	N/A
	2) when temperatures affected solder or solder joints causing loosening, short circuiting, or other failures causing sparking or increasing material temperature to its ignition temperature	EUT is not intended to be used in conjunction with Oxygen rich environment	N/A
	3) when parts affecting safety cracked or changed outer shape exposing temperatures higher than 300°C or sparks due to overheating	EUT is not intended to be used in conjunction with Oxygen rich environment	N/A
	4) when temperatures of parts or components exceeded 300°C, atmosphere was 100 % oxygen, contact material solder, and fuel cotton	EUT is not intended to be used in conjunction with Oxygen rich environment	N/A
	5) when sparks provided adequate energy for ignition by exceeding limits of Figs 35 to 37 (inclusive), atmosphere was 100 % oxygen, contact material solder, and fuel cotton	EUT is not intended to be used in conjunction with Oxygen rich environment	N/A
	Deviations from worst case limits in 4) and 5) above based on lower oxygen concentrations or less flammable fuels justified and documented in RISK MANAGEMENT FILE	EUT is not intended to be used in conjunction with Oxygen rich environment	N/A
	Alternative test in this clause did not identify existence of ignition sources at highest voltage or current, respectively	EUT is not intended to be used in conjunction with Oxygen rich environment	N/A
	A safe upper limit determined by dividing upper limit of voltage or current, respectively, with safety margin factor of three..... :	EUT is not intended to be used in conjunction with Oxygen rich environment	N/A
	b) RESIDUAL RISK of fire in an OXYGEN RICH ENVIRONMENT as determined by application of RISK MANAGEMENT PROCESS is based on following configurations, or in combination	EUT is not intended to be used in conjunction with Oxygen rich environment	N/A
	1) Electrical components in an OXYGEN RICH ENVIRONMENT provided with power supplies having limited energy levels lower than those considered sufficient for ignition in 11.2.2.1 a) as determined by examination, measurement or calculation of power, energy, and temperatures in NORMAL and SINGLE FAULT CONDITIONS identified in 11.2.3..... :	EUT is not intended to be used in conjunction with Oxygen rich environment	N/A

IEC 60601-1			
Clause	Requirement + Test	Result - Remark	Verdict
	2) Max oxygen concentration measured until it did not exceed 25 % in ventilated compartments with parts that can be a source of ignition only in SINGLE FAULT CONDITION and can be penetrated by oxygen due to an undetected leak (%)..... :	EUT is not intended to be used in conjunction with Oxygen rich environment	N/A
	3) A compartment with parts or components that can be a source of ignition only under SINGLE FAULT CONDITION separated from another compartment containing an OXYGEN RICH ENVIRONMENT by sealing all joints and holes for cables, shafts, or other purposes	EUT is not intended to be used in conjunction with Oxygen rich environment	N/A
	Effect of possible leaks and failures under SINGLE FAULT CONDITION that could cause ignition evaluated using a RISK ASSESSMENT to determine maintenance intervals by examination of documentation and RISK MANAGEMENT FILE..... :	EUT is not intended to be used in conjunction with Oxygen rich environment	N/A
	4) Fire initiated in ENCLOSURE of electrical components in a compartment with OXYGEN RICH ENVIRONMENT that can become a source of ignition only under SINGLE FAULT CONDITIONS self-extinguished rapidly and no hazardous amount of toxic gases reached PATIENT as determined by analysis of gases :	EUT is not intended to be used in conjunction with Oxygen rich environment	N/A
11.2.2.2	RISK of ignition under least favourable conditions did not occur and oxygen concentration did not exceed 25% in immediate surroundings due to location of external exhaust outlets of an OXYGEN RICH ENVIRONMENT when electrical components mounted outside of ME EQUIPMENT OR ME SYSTEM	EUT is not intended to be used in conjunction with Oxygen rich environment	N/A
11.2.2.3	Electrical connections within a compartment containing an OXYGEN RICH ENVIRONMENT under NORMAL USE did not produce sparks due to loosening or breaking, except when limited in power and energy to values in 11.2.2.1 a) 5)	EUT is not intended to be used in conjunction with Oxygen rich environment	N/A
	– Screw-attachments protected against loosening during use by varnishing, use of spring washers, or adequate torques	EUT is not intended to be used in conjunction with Oxygen rich environment	N/A
	– Soldered, crimped, and pin-and-socket connections of cables exiting ENCLOSURE include additional mechanical securing means	EUT is not intended to be used in conjunction with Oxygen rich environment	N/A
11.2.3	SINGLE FAULT CONDITIONS related to OXYGEN RICH ENVIRONMENTS ME EQUIPMENT and ME SYSTEMS considered		
	– Failure of a ventilation system constructed in accordance with 11.2.2.1 b) 2)..... :	EUT is not intended to be used in conjunction with Oxygen rich environment	N/A
	– Failure of a barrier constructed in accordance with 11.2.2.1 b) 3)..... :	EUT is not intended to be used in conjunction with Oxygen rich environment	N/A

IEC 60601-1			
Clause	Requirement + Test	Result - Remark	Verdict
	– Failure of a component creating a source of ignition (as defined in 11.2.2.1 a)	EUT is not intended to be used in conjunction with Oxygen rich environment	N/A
	– Failure of solid insulation or creepage and clearances providing equivalent of at least one MEANS OF PATIENT PROTECTION but less than two MEANS OF PATIENT PROTECTION that could create a source of ignition defined in 11.2.2.1 a)	EUT is not intended to be used in conjunction with Oxygen rich environment	N/A
	– Failure of a pneumatic component resulting in leakage of oxygen-enriched gas.....	EUT is not intended to be used in conjunction with Oxygen rich environment	N/A
11.3	Constructional requirements for fire ENCLOSURES of ME EQUIPMENT		
	ME EQUIPMENT met this clause for alternate means of compliance with selected HAZARDOUS SITUATIONS and fault conditions in 13.1.2.....	RMF check is not included in this evaluation	N/E
	Constructional requirements were met, or		P
	- constructional requirements specifically analysed in RISK MANAGEMENT FILE	Constructional requirements met	N/A
	Justification, when requirement not met	Constructional requirements met	N/A
	a) Flammability classification of insulated wire within fire ENCLOSURE is FV-1, or better, based on IEC 60695 series as determined by examination of data on materials	See appended Table 8.10	P
	Flammability classification of connectors, printed circuit boards, and insulating material on which components are mounted is FV-2, or better, based on IEC 60695-11-10 as decided by examination of materials data	See appended Table 8.10	P
	If no FV Certification, FV tests based on IEC 60695-11-10 conducted on 3 samples of complete parts (or sections of it), including area with min. thickness, ventilation openings	With FV certification	N/A
	b) Fire ENCLOSURE met following:		P
	1) No openings at bottom or, as specified in Fig 39, constructed with baffles as in Fig 38, or made of perforated metal as in Table 25, or a metal screen with a mesh $\leq 2 \times 2$ mm centre to centre and wire diameter of at least 0.45 mm	No opening at bottom	P
	2) No openings on the sides within the area included within the inclined line C in Fig 39	No opening on sides	P

IEC 60601-1			
Clause	Requirement + Test	Result - Remark	Verdict
	3) ENCLOSURE, baffles, and flame barriers have adequate rigidity and made of appropriate metal or of non-metallic materials, except constructions based on Table 25 and a mesh; FV-2 or better for TRANSPORTABLE ME EQUIPMENT, FV-1 or better for fixed EQUIPMENT, or STATIONARY EQUIPMENT per IEC 60695-11-10, determined by ENCLOSURE examination or flammability classification based on 11.3a)..... :	See appended Table 8.10	P
11.4	ME EQUIPMENT and ME SYSTEMS intended for use with flammable anaesthetics		
	ME EQUIPMENT, ME SYSTEMS and parts described in ACCOMPANYING DOCUMENTS for use with flammable anaesthetics (CATEGORY AP) or anaesthetics with oxidants (CATEGORY APG) comply with Annex G	Not intended for use with flammable anaesthetics	N/A
11.5	ME EQUIPMENT and ME SYSTEMS intended for use in conjunction with flammable agents		
	MANUFACTURER'S RISK MANAGEMENT PROCESS addresses possibility of fire and associated mitigations as confirmed by examination of RISK MANAGEMENT FILE	Not intended for use with flammable agents	N/A
11.6	Overflow, spillage, leakage, ingress of water or particulate matter, cleaning, disinfection, sterilization and compatibility with substances used with the ME EQUIPMENT		
11.6.1	Sufficient degree of protection provided against overflow, spillage, leakage, ingress of water or particulate matter, cleaning, disinfection and sterilization, and compatibility with substances used with ME EQUIPMENT..... :	See Appended Table 11.6.1	P
11.6.2	Overflow in ME EQUIPMENT		
	Liquid reservoir liable to overflow in NORMAL USE completely filled and 15 % of its capacity poured in for over 1 min, and except when restricted, TRANSPORTABLE ME EQUIPMENT tilted through an angle of 15° in least favourable direction(s), and when necessary refilled starting from position of NORMAL USE..... :	No water used	N/A
	ME EQUIPMENT met dielectric strength and LEAKAGE CURRENT tests and uninsulated electrical parts or electrical insulation of parts that could result in a HAZARDOUS SITUATION were not wet..... :	No water used	N/A
11.6.3	Spillage on ME EQUIPMENT and ME SYSTEM		
	ME EQUIPMENT and ME SYSTEMS handling liquids in NORMAL USE positioned as in 5.4 a) and liquid with composition, volume, duration of spill, point of contact, and test conditions based on RISK MANAGEMENT PROCESS poured steadily on a point on top of ME EQUIPMENT	No water used	N/A

IEC 60601-1			
Clause	Requirement + Test	Result - Remark	Verdict
	ME EQUIPMENT met dielectric strength and LEAKAGE CURRENT tests and uninsulated electrical parts or electrical insulation of parts that could result in a HAZARDOUS SITUATION were not wet	No water used	N/A
11.6.4	Leakage	No water used	N/A
11.6.5	Ingress of water or particulate matter into ME EQUIPMENT and ME SYSTEMS		
	ME EQUIPMENT with IP Code placed in least favourable position of NORMAL USE and subjected to tests of IEC 60529 (IP Code).....	IP20	N/A
	ME EQUIPMENT met dielectric strength and LEAKAGE CURRENT tests and there were no bridging of insulation or electrical components that could result in a HAZARDOUS SITUATION in NORMAL CONDITION or in a SINGLE FAULT CONDITION	IP20	N/A
11.6.6	Cleaning and disinfection of ME EQUIPMENT and ME SYSTEMS		
	ME EQUIPMENT/ME SYSTEM and their parts and ACCESSORIES cleaned or disinfected once using methods specified in instructions for use including any cooling or drying period	RMF check is not included in this evaluation	N/E
	ME EQUIPMENT met dielectric strength and LEAKAGE CURRENT tests, with no deterioration resulting in an unacceptable RISK present	See appended Tables 8.7 8.8.3	P
	Effects of multiple cleanings/disinfections during EXPECTED SERVICE LIFE of EQUIPMENT evaluated by MANUFACTURER and assurance that no unacceptable RISK will occur verified by RISK MANAGEMENT FILE review.....	RMF check is not included in this evaluation	N/E
11.6.7	Sterilization of ME EQUIPMENT and ME SYSTEMS		
	ME EQUIPMENT, ME SYSTEMS and their parts or ACCESSORIES intended to be sterilized assessed and documented according to ISO 11134, ISO 11135, or ISO 11137 as appropriate	No sterilization required	N/A
	After the test, ME EQUIPMENT complied with the appropriate dielectric strength and LEAKAGE CURRENT tests and there was no deterioration resulting in an unacceptable RISK	No sterilization required	N/A
11.6.8	RISKS associated with compatibility of substances used with ME EQUIPMENT addressed in RISK MANAGEMENT PROCESS as confirmed by examination of RISK MANAGEMENT FILE.....	RMF check is not included in this evaluation	N/E
11.7	ME EQUIPMENT, ME SYSTEM, and ACCESSORIES coming into direct or indirect contact with biological tissues, cells, or body fluids assessed and documented per ISO 10993	Biocompatibility is not included in this evaluation	N/E

IEC 60601-1			
Clause	Requirement + Test	Result - Remark	Verdict
11.8	Interruption and restoration of power supply did not result in a HAZARDOUS SITUATION, except interruption of its intended function		P
12	ACCURACY OF CONTROLS AND INSTRUMENTS AND PROTECTION AGAINST HAZARDOUS OUTPUTS		
12.1	RISKS associated with accuracy of controls and instruments stated in RISK MANAGEMENT PROCESS confirmed by RISK MANAGEMENT FILE review :	No output	N/A
12.2	RISK of poor USABILITY, including identification, marking, and documents addressed in a USABILITY ENGINEERING PROCESS as confirmed by review of provided records..... :	Usability is not included in this evaluation	N/E
12.3	The need for alarm systems as a means of RISK CONTROL and RISKS associated with operation or failure of alarm system addressed in RISK MANAGEMENT PROCESS	No output	N/A
12.4	Protection against hazardous output		
12.4.1	RISKS associated with hazardous output arising from intentional exceeding of safety limits addressed in RISK MANAGEMENT PROCESS as confirmed in RISK MANAGEMENT FILE	No output	N/A
12.4.2	When applicable, need for indication of parameters associated with hazardous output addressed in RISK MANAGEMENT PROCESS as confirmed in RISK MANAGEMENT FILE	No output	N/A
12.4.3	RISKS associated with accidental selection of excessive output values for ME EQUIPMENT with a multi-purpose unit designed to provide low and high-intensity outputs for different treatments addressed in RISK MANAGEMENT PROCESS, confirmed in RISK MANAGEMENT FILE .. :	No output	N/A
12.4.4	When applicable, RISKS associated with incorrect output addressed in RISK MANAGEMENT PROCESS as confirmed by review of RISK MANAGEMENT FILE	No output	N/A
12.4.5	Diagnostic or therapeutic radiation		
12.4.5.1	Adequate provisions to protect OPERATORS, PATIENTS, other persons and sensitive devices in vicinity of unwanted or excessive radiation emitted by ME EQUIPMENT designed to produce radiation for diagnostic/therapeutic purposes	No output	N/A
	Radiation safety ensured by compliance with requirements of appropriate standards	No output	N/A
12.4.5.2	RISKS associated with diagnostic X-rays addressed in RISK MANAGEMENT PROCESS as confirmed in RISK MANAGEMENT FILE	No output	N/A

IEC 60601-1			
Clause	Requirement + Test	Result - Remark	Verdict
12.4.5.3	RISKS associated with radiotherapy addressed in RISK MANAGEMENT PROCESS as confirmed by review of RISK MANAGEMENT FILE	No output	N/A
12.4.5.4	RISKS associated with ME EQUIPMENT producing diagnostic or therapeutic radiation other than diagnostic X-rays and radiotherapy addressed in RISK MANAGEMENT PROCESS as confirmed by examination of RISK MANAGEMENT FILE.....	No output	N/A
12.4.6	When applicable, RISKS associated with diagnostic or therapeutic acoustic pressure addressed in RISK MANAGEMENT PROCESS as confirmed in RISK MANAGEMENT FILE	No output	N/A

13	HAZARDOUS SITUATIONS AND FAULT CONDITIONS		
13.1	Specific HAZARDOUS SITUATIONS		
13.1.1	None of HAZARDOUS SITUATIONS in 13.1.2-13.1.4, inclusive, occurred when SINGLE FAULT CONDITIONS applied, one at a time, as in 4.7 and 13.2	None of these situations occurred	P
13.1.2	Emissions, deformation of ENCLOSURE or exceeding maximum temperature		
	– Emission of flames, molten metal, poisonous or ignitable substance in hazardous quantities did not occur		P
	– Deformation of ENCLOSURE impairing compliance with 15.3.1 did not occur		P
	– Temperatures of APPLIED PARTS did not exceed allowable values in Table 24 when measured as in 11.1.3.....	See appended Tables 11.1.1, 11.1.2.1, and 11.1.2.2	P
	– Temperatures of ME EQUIPMENT parts that are not APPLIED PARTS likely to be touched did not exceed values in Table 23 when measured and adjusted as in 11.1.3.....	See appended Tables 11.1.1, 11.1.2.1, and 11.1.2.2	P
	–Allowable values for “other components and materials” in Table 22 times 1.5 minus 12.5 °C were not exceeded		P
	Limits for windings in Tables 26, 27, and 31 not exceeded	No winding	N/A
	Table 22 not exceeded in all other cases		P
	Temperatures measured according to 11.1.3		P
	SINGLE FAULT CONDITIONS in 4.7, 8.1 b), 8.7.2, and 13.2.2 relative to emission of flames, molten metal, or ignitable substances, not applied to parts and components where:		P
	– Supply circuit was unable to supply 15 W one minute after 15 W drawn from supply circuit, or	Powered by battery	N/A

IEC 60601-1			
Clause	Requirement + Test	Result - Remark	Verdict
	– Parts and components completely contained within a fire ENCLOSURE complying with 11.3 as verified by review of design documentation		P
	After tests of this Clause, settings of THERMAL CUT-OUTS and OVER-CURRENT RELEASES did not change sufficiently to affect their safety function	No such part	N/A
13.1.3	– limits for LEAKAGE CURRENT in SINGLE FAULT CONDITION based on 8.7.3 did not exceed..... :	See appended Table 8.7	P
	– voltage limits for ACCESSIBLE PARTS including APPLIED PARTS in 8.4.2 did not exceed :	See appended Table 8.7	P
13.1.4	ME EQUIPMENT complied with the requirements of 9.1 to 9.8 for specific MECHANICAL HAZARDS		P
13. 2	SINGLE FAULT CONDITIONS		
13.2.1	During application of SINGLE FAULT CONDITIONS in 13.2.2 -13.2.13, inclusive, NORMAL CONDITIONS in 8.1 a) applied in least favourable combination :	See appended Table 13.2	P
13.2.2 – 13.2.12	ME EQUIPMENT complied with 13.2.2 -13.2.12..... :	See appended Table 13.2	P
13.2.13	ME EQUIPMENT remained safe after tests of 13.2.13.2 to 13.2.13.4 (inclusive), and cooling down to room temperature		P
	ME EQUIPMENT examined for compliance or appropriate tests such as dielectric strength of motor insulation according to 8.8.3 conducted	No motor	N/A
	For insulation of thermoplastic materials relied upon as a MEANS OF PROTECTION (see 8.8), the ball-pressure test specified in 8.8.4.1 a) performed at a temperature 25 °C higher than temperature of insulation measured during tests of 13.2.13.2 to 13.2.13.4 (inclusive).	Tests of 13.2.13.2 to 13.2.13.4 are not applicable	N/A
13.2.13.2	ME EQUIPMENT with heating elements		
	a 1) thermostatically controlled ME EQUIPMENT with heating elements for building-in, or for unattended operation, or with a capacitor not protected by a fuse connected in parallel with THERMOSTAT contacts met tests of 13.2.13.2 b) & 13.2.13.2 c)	No heating element	N/A
	a 2) ME EQUIPMENT with heating elements RATED for non-CONTINUOUS OPERATION met tests of 13.2.13.2 b) and 13.2.13.2 c)	No heating element	N/A
	a 3) other ME EQUIPMENT with heating elements met test of 13.2.13.2 b)	No heating element	N/A
	When more than one test was applicable to same ME EQUIPMENT, tests performed consecutively	No heating element	N/A

IEC 60601-1			
Clause	Requirement + Test	Result - Remark	Verdict
	Heating period stopped when a heating element or an intentionally weak part of a non-SELF-RESETTING THERMAL CUT-OUT ruptured, or current interrupted before THERMAL STABILITY without possibility of automatic restoration	No heating element	N/A
	Test repeated on a second sample when interruption was due to rupture of a heating element or an intentionally weak part	No heating element	N/A
	Both samples met 13.1.2, and open circuiting of a heating element or an intentionally weak part in second sample not considered a failure by itself	No heating element	N/A
	b) ME EQUIPMENT with heating elements tested per 11.1 without adequate heat discharge, and supply voltage set at 90 or 110 % of RATED supply voltage, least favourable of the two (V) : :	No heating element	N/A
	Operating period stopped when a non-SELF-RESETTING THERMAL CUT-OUT operated, or current interrupted without possibility of automatic restoration before THERMAL STABILITY	No heating element	N/A
	ME EQUIPMENT switched off as soon as THERMAL STABILITY established and allowed to cool to room temperature when current not interrupted	No heating element	N/A
	Test duration was equal to RATED operating time for non-CONTINUOUS OPERATION	No heating element	N/A
	c) Heating parts of ME EQUIPMENT tested with ME EQUIPMENT operated in NORMAL CONDITION at 110 % of RATED supply voltage and as in 11.1, and	No heating element	N/A
	1) Controls limiting temperature in NORMAL CONDITION disabled, except THERMAL CUT-OUTS	No heating element	N/A
	2) When more than one control provided, they were disabled in turn	No heating element	N/A
	3) ME EQUIPMENT operated at RATED DUTY CYCLE until THERMAL STABILITY achieved, regardless of RATED operating time	No heating element	N/A
13.2.13.3	ME EQUIPMENT with motors		
	a 1) For the motor part of the ME EQUIPMENT, compliance checked by tests of 13.2.8- 13.2.10, 13.2.13.3 b), 13.2.13.3 c), and 13.2.13.4, as applicable	No motor	N/A
	To determine compliance with 13.2.9 and 13.2.10 motors in circuits running at 42.4 V peak a.c./ 60 V d.c. or less are covered with a single layer of cheesecloth which did not ignite during the test	No motor	N/A

IEC 60601-1			
Clause	Requirement + Test	Result - Remark	Verdict
	a 2) Tests on ME EQUIPMENT containing heating parts conducted at prescribed voltage with motor & heating parts operated simultaneously to produce the least favourable condition	No motor	N/A
	a 3) Tests performed consecutively when more tests were applicable to the same ME EQUIPMENT	No motor	N/A
	b) Motor met running overload protection test of this clause when:	No motor	N/A
	1) it is intended to be remotely or automatically controlled by a single control device with no redundant protection, or	No motor	N/A
	2) it is likely to be subjected to CONTINUOUS OPERATION while unattended	No motor	N/A
	Motor winding temperature determined during each steady period and maximum value did not exceed Table 27 (Insulation Class, Maximum temperature measured °C)..... :	No motor	N/A
	Motor removed from ME EQUIPMENT and tested separately when load could not be changed in appropriate steps	No motor	N/A
	Running overload test for motors operating at 42.4 V peak a.c./60 V d.c. or less performed only when examination and review of design indicated possibility of an overload	No motor	N/A
	Test not conducted where electronic drive circuits maintained a substantially constant drive current	No motor	N/A
	Test not conducted based on other justifications (justification)..... :	No motor	N/A
	c) ME EQUIPMENT with 3-phase motors operated with normal load, connected to a 3-phase SUPPLY MAINS with one phase disconnected, and periods of operation per 13.2.10	No motor	N/A
13.2.13.4	ME EQUIPMENT RATED for NON-CONTINUOUS OPERATION		
	ME EQUIPMENT (other than HAND-HELD) operated under normal load and at RATED voltage or at upper limit of RATED voltage range until increase in temperature was ≤ 5 °C in one hour, or a protective device operated	Continuous operation	N/A
	When a load-reducing device operated in NORMAL USE, test continued with ME EQUIPMENT running idle	Continuous operation	N/A
	Motor winding temperatures did not exceed values in 13.2.10	Continuous operation	N/A
	Insulation Class	Continuous operation	—
	Maximum temperature measured (°C)..... :	Continuous operation	—

IEC 60601-1			
Clause	Requirement + Test	Result - Remark	Verdict
14	PROGRAMMABLE ELECTRICAL MEDICAL SYSTEMS (PEMS)		
14.1	Requirements of this clause not applied to PESS when it provided no BASIC SAFETY or ESSENTIAL PERFORMANCE, or	PEMS check is not included in this evaluation	N/E
	- when application of ISO 14971 showed that failure of PESS does not lead to unacceptable RISK	PEMS check is not included in this evaluation	N/E
	Every PROCESS has been followed throughout the PEMS DEVELOPMENT LIFE-CYCLE and a RECORD of PROCESS has been made available as confirmed by RISK MANAGEMENT FILE REVIEW and assessment of PROCESSES cited in this Clause	PEMS check is not included in this evaluation	N/E
	MANUFACTURER considered the need for additional RISK CONTROL measures when unable to follow all PROCESSES identified in Clause 14 for each constituent component of PEMS as confirmed by RISK MANAGEMENT FILE review and assessment of PROCESSES cited in this Clause	PEMS check is not included in this evaluation	N/E
	Assessment of PROCESSES cited in this Clause made by internal audits	PEMS check is not included in this evaluation	N/E
14.2	Documents produced from application of Clause 14 are maintained and form a part of RISK MANAGEMENT FILE in addition to RECORDS and documents required by ISO 14971	PEMS check is not included in this evaluation	N/E
14.3	RISK MANAGEMENT plan required by 3.5 of ISO 14971 includes reference to PEMS VALIDATION plan	PEMS check is not included in this evaluation	N/E
14.4	A PEMS DEVELOPMENT LIFE-CYCLE including a set of defined milestones has been documented	PEMS check is not included in this evaluation	N/E
	At each milestone, activities to be completed, and VERIFICATION methods to be applied to activities have been defined	PEMS check is not included in this evaluation	N/E
	Each activity including its inputs and outputs defined, and each milestone identifies RISK MANAGEMENT activities that must be completed before that milestone	PEMS check is not included in this evaluation	N/E
	PEMS DEVELOPMENT LIFE-CYCLE tailored for a specific development by making plans detailing activities, milestones, and schedules	PEMS check is not included in this evaluation	N/E
	PEMS DEVELOPMENT LIFE-CYCLE includes documentation requirements	PEMS check is not included in this evaluation	N/E
14.5	A documented system for problem resolution within and between all phases and activities of PEMS DEVELOPMENT LIFE-CYCLE has been developed and maintained where appropriate	PEMS check is not included in this evaluation	N/E

IEC 60601-1			
Clause	Requirement + Test	Result - Remark	Verdict
	Problem resolution system meets the prescribed criteria depending on type of product:	PEMS check is not included in this evaluation	N/E
	– it is documented as a part of PEMS DEVELOPMENT LIFE-CYCLE	PEMS check is not included in this evaluation	N/E
	– it allows reporting of potential or existing problems affecting BASIC SAFETY or ESSENTIAL PERFORMANCE	PEMS check is not included in this evaluation	N/E
	– it includes an assessment of each problem for associated RISKS	PEMS check is not included in this evaluation	N/E
	– it identifies criteria that must be met for the issue to be closed	PEMS check is not included in this evaluation	N/E
	– it identifies the action to be taken to resolve each problem	PEMS check is not included in this evaluation	N/E
14.6	RISK MANAGEMENT PROCESS		
14.6.1	MANUFACTURER considered HAZARDS associated with software and hardware aspects of PEMS including NETWORK/DATA COUPLING, components of third-party origin, legacy subsystems when compiling list of known or foreseeable HAZARDS	PEMS check is not included in this evaluation	N/E
	In addition to the material in ISO 14971, Annex D, list of possible sources for HAZARDS associated with PEMS includes specified causes	PEMS check is not included in this evaluation	N/E
	– failure of NETWORK/DATA COUPLING to provide characteristics necessary for PEMS to achieve its BASIC SAFETY or ESSENTIAL PERFORMANCE	PEMS check is not included in this evaluation	N/E
	– undesired feedback [physical and data] (such as unsolicited/ out of range/ inconsistent input or input from electromagnetic interference)	PEMS check is not included in this evaluation	N/E
	– unavailable data	PEMS check is not included in this evaluation	N/E
	– lack of integrity of data	PEMS check is not included in this evaluation	N/E
	– incorrect data	PEMS check is not included in this evaluation	N/E
	– incorrect timing of data	PEMS check is not included in this evaluation	N/E
	– unintended interactions within & among PESS	PEMS check is not included in this evaluation	N/E
	– unknown aspects or quality of third-party software	PEMS check is not included in this evaluation	N/E
	– unknown aspects or quality of third-party PESS	PEMS check is not included in this evaluation	N/E

IEC 60601-1			
Clause	Requirement + Test	Result - Remark	Verdict
	– lack of data security, particularly vulnerability to tampering, unintended interaction with other programs and viruses	PEMS check is not included in this evaluation	N/E
14.6.2	Suitably validated tools and PROCEDURES assuring each RISK CONTROL measure reduces identified RISK(S) satisfactorily provided in addition to PEMS requirements in Clause 6.1 of ISO 14971	PEMS check is not included in this evaluation	N/E
14.7	A documented requirement specification for PEMS and each of its subsystems (e.g. for a PESS) which includes ESSENTIAL PERFORMANCE and RISK CONTROL measures implemented by that system or subsystem	PEMS check is not included in this evaluation	N/E
14.8	An architecture satisfying the requirement is specified for PEMS and each of subsystems	PEMS check is not included in this evaluation	N/E
	The architecture specification makes use of considers the specified items to reduce RISK to an acceptable level, where appropriate:	PEMS check is not included in this evaluation	N/E
	a) COMPONENTS WITH HIGH-INTEGRITY CHARACTERISTICS	PEMS check is not included in this evaluation	N/E
	b) fail-safe functions	PEMS check is not included in this evaluation	N/E
	c) redundancy	PEMS check is not included in this evaluation	N/E
	d) diversity;	PEMS check is not included in this evaluation	N/E
	e) partitioning of functionality	PEMS check is not included in this evaluation	N/E
	f) defensive design potentially limiting hazardous effects by restricting available output power or by introducing means to limit travel of actuators	PEMS check is not included in this evaluation	N/E
	g) allocation of RISK CONTROL measures to subsystems and components of PEMS	PEMS check is not included in this evaluation	N/E
	h) failure modes of components and their effects;	PEMS check is not included in this evaluation	N/E
	i) common cause failures	PEMS check is not included in this evaluation	N/E
	j) systematic failures	PEMS check is not included in this evaluation	N/E
	k) test interval duration and diagnostic coverage	PEMS check is not included in this evaluation	N/E
	l) maintainability	PEMS check is not included in this evaluation	N/E
	m) protection from reasonably foreseeable misuse	PEMS check is not included in this evaluation	N/E

IEC 60601-1			
Clause	Requirement + Test	Result - Remark	Verdict
	n) NETWORK/DATA COUPLING specification, when applicable	PEMS check is not included in this evaluation	N/E
14.9	Design is broken up into subsystems, each with a design and test specification where appropriate, and descriptive data on design environment included in RISK MANAGEMENT FILE :	PEMS check is not included in this evaluation	N/E
14.10	A VERIFICATION plan containing the specified information used to verify and document functions implementing BASIC SAFETY, ESSENTIAL PERFORMANCE, OR RISK CONTROL measures :	PEMS check is not included in this evaluation	N/E
	– milestone(s) when VERIFICATION is to be performed for each function	PEMS check is not included in this evaluation	N/E
	– selection and documentation of VERIFICATION strategies, activities, techniques, and appropriate level of independence of the personnel performing the VERIFICATION	PEMS check is not included in this evaluation	N/E
	– selection and utilization of VERIFICATION tools	PEMS check is not included in this evaluation	N/E
	– coverage criteria for VERIFICATION	PEMS check is not included in this evaluation	N/E
14.11	A PEMS VALIDATION plan containing validation of BASIC SAFETY & ESSENTIAL PERFORMANCE and requiring checks for unintended functioning of PEMS to perform and document PEMS VALIDATION	PEMS check is not included in this evaluation	N/E
	The person with overall responsibility for PEMS VALIDATION is independent of design team, and no member of a design team is responsible for PEMS VALIDATION of their own design	PEMS check is not included in this evaluation	N/E
	All professional relationships of members of PEMS VALIDATION team with members of design team documented in RISK MANAGEMENT FILE providing methods & results of PEMS VALIDATION	PEMS check is not included in this evaluation	N/E
14.12	Continued validity of previous design documentation assessed under a documented modification/change PROCEDURE	PEMS check is not included in this evaluation	N/E
14.13	Technical description includes the following information when PEMS is to be connected to other equipment outside control of PEMS MANUFACTURER by NETWORK/DATA COUPLING :	PEMS check is not included in this evaluation	N/E
	a) characteristics of NETWORK/DATA COUPLING necessary for PEMS to achieve its INTENDED USE	PEMS check is not included in this evaluation	N/E
	b) list of HAZARDOUS SITUATIONS resulting from a failure of NETWORK/DATA COUPLING to provide the specified characteristics	PEMS check is not included in this evaluation	N/E
	c) instructions to RESPONSIBLE ORGANIZATION containing required information and warnings	PEMS check is not included in this evaluation	N/E

IEC 60601-1			
Clause	Requirement + Test	Result - Remark	Verdict
	– connection of PEMS to a NETWORK/DATA COUPLING that includes other equipment could result in previously unidentified RISKS and RESPONSIBLE ORGANIZATION shall identify, analyze, and control such RISKS	PEMS check is not included in this evaluation	N/E
	– subsequent changes to NETWORK/DATA COUPLING introducing new RISKS and requiring new analysis; and changes to NETWORK/DATA COUPLING include:	PEMS check is not included in this evaluation	N/E
	– NETWORK/DATA COUPLING configuration change	PEMS check is not included in this evaluation	N/E
	– connection of additional items to NETWORK/DATA COUPLING	PEMS check is not included in this evaluation	N/E
	– disconnecting items from NETWORK/DATA COUPLING	PEMS check is not included in this evaluation	N/E
	– update of equipment connected to NETWORK/DATA COUPLING	PEMS check is not included in this evaluation	N/E
	– upgrade of equipment connected to NETWORK/DATA COUPLING	PEMS check is not included in this evaluation	N/E
15	CONSTRUCTION OF ME EQUIPMENT		
15.1	RISKS associated with arrangement of controls and indicators of ME EQUIPMENT addressed in RISK MANAGEMENT PROCESS, as confirmed by examination of RISK MANAGEMENT FILE :	RMF check is not included in this evaluation	N/E
15.2	Parts of ME EQUIPMENT subject to mechanical wear, electrical, environmental degradation or ageing resulting in unacceptable RISK when unchecked for a long period, are accessible for inspection, replacement, and maintenance		P
	Inspection, servicing, replacement, and adjustment of parts of ME EQUIPMENT can easily be done without damage to or interference with adjacent parts or wiring		P
15.3	Mechanical strength		
15.3.1	Mold stress relief, push, impact, drop, and rough handling tests did not result in unacceptable RISK and ME EQUIPMENT displayed adequate mechanical strength		P
15.3.2	Push test conducted by subjecting external parts of ENCLOSURE to a steady force of 250 N \pm 10 N for 5 s applied to a circular (30mm) plane surface, except bottom of ENCLOSURE of an ME EQUIPMENT >18 kg, using a suitable test tool ... :	See Appended Table 15.3	P
	No damage resulting in an unacceptable RISK sustained as determined by examination of RISK MANAGEMENT FILE	RMF check is not included in this evaluation	N/E

IEC 60601-1			
Clause	Requirement + Test	Result - Remark	Verdict
15.3.3	Impact test conducted by subjecting a complete ENCLOSURE or its largest non-reinforced area, except for HAND-HELD ME EQUIPMENT and parts, to a free falling 500 g ± 25 g solid smooth steel ball, approx. 50 mm in diameter from a height of 1.3 m	See Appended Table 15.3	P
	Test not applied to flat panel displays, platen glass of ME EQUIPMENT, or cathode ray tubes	No such part	N/A
	No damage resulting in an unacceptable RISK sustained as shown in RISK MANAGEMENT FILE		P
15.3.4	Drop test		
15.3.4.1	Sample of HAND-HELD ME EQUIPMENT and HAND-HELD part with SAFE WORKING LOAD allowed to fall freely once from each of 3 different positions as in NORMAL USE from height specified in ACCOMPANYING DOCUMENTS, or from 1 m onto a 50 mm ± 5 mm thick hardwood board lying flat on a concrete or rigid base.....	Not hand-held	N/A
	No unacceptable RISK resulted	Not hand-held	N/A
15.3.4.2	Sample of PORTABLE ME EQUIPMENT and PORTABLE part with SAFE WORKING LOAD lifted to a height as in Table 29 above a 50 ± 5 mm thick hardwood board lying flat on a concrete floor or rigid base, dropped 3 times from each orientation in NORMAL USE (cm)	Not portable	N/A
	No damage resulting in an unacceptable RISK sustained as determined by examination of sample and RISK MANAGEMENT FILE	RMF check is not included in this evaluation	N/E
15.3.5	Each sample of MOBILE ME EQUIPMENT and MOBILE part with SAFE WORKING LOAD and in most adverse condition in NORMAL USE passed Rough Handling tests	Not mobile	N/A
	a) Ascending step shock test conducted on the sample by pushing it 3 times in its normal direction of travel at 0.4 m/s ± 0.1 m/s against an ascending hardwood step obstruction without the sample going over the obstruction	Not mobile	N/A
	b) Descending step shock test conducted on the sample by pushing it 3 times in its normal direction of travel at 0.4 m/s ± 0.1 m/s in order to fall over a vertical step affixed flat on a rigid base with direction of movement perpendicular to face of the step until full descent achieved	Not mobile	N/A
	c) Door frame shock test conducted on the sample by moving it 3 times in its normal direction of travel at 0.4 m/s ± 0.1 m/s, or for motor driven EQUIPMENT, at maximum possible speed against a hardwood vertical obstacle higher than EQUIPMENT contact point(s)	Not mobile	N/A

IEC 60601-1			
Clause	Requirement + Test	Result - Remark	Verdict
	No damage resulting in an unacceptable RISK sustained as determined by examination of sample and RISK MANAGEMENT FILE	Not mobile	N/A
15.3.6	Examination of ENCLOSURE made from molded or formed thermoplastic material indicated that material distortion due to release of internal stresses by molding or forming operations will not result in an unacceptable RISK		P
	Mold-stress relief test conducted by placing one sample of complete ME EQUIPMENT, ENCLOSURE or a portion of larger ENCLOSURE, for 7 hours in a circulating air oven at 10°C over the max temperature measured on ENCLOSURE in 11.1.3, but no less than 70 °C		P
	No damage resulting in an unacceptable RISK		P
15.3.7	INTENDED USE, EXPECTED SERVICE LIFE, and conditions for transport and storage were taken into consideration for selection and treatment of materials used in construction of ME EQUIPMENT		P
	Based on review of EQUIPMENT, ACCOMPANYING DOCUMENTS, specifications and processing of materials, and MANUFACTURER'S relevant tests or calculations, corrosion, ageing, mechanical wear, degradation of biological materials due to bacteria, plants, animals and the like, will not result in an unacceptable RISK		P
15.4	ME EQUIPMENT components and general assembly		
15.4.1	Incorrect connection of accessible connectors, removable without a TOOL, prevented where an unacceptable RISK exists, in particular	RMF check is not included in this evaluation	N/E
	a) Plugs for connection of PATIENT leads cannot be connected to other outlets on same ME EQUIPMENT intended for other functions, except when RISK MANAGEMENT FILE provides proof that no unacceptable RISK could result	No patient leads	N/A
	b) Medical gas connections on ME EQUIPMENT for different gases to be operated in NORMAL USE are not interchangeable as verified by review of RISK MANAGEMENT FILE	No gas connection	N/A
15.4.2	Temperature and overload control devices		
15.4.2.1	a) THERMAL CUT-OUTS and OVER-CURRENT RELEASES with automatic resetting not used in ME EQUIPMENT when their use could result in a HAZARDOUS SITUATION by resetting action as verified by review of RISK MANAGEMENT FILE	No temperature / overload control device	N/A

IEC 60601-1			
Clause	Requirement + Test	Result - Remark	Verdict
	b) THERMAL CUT-OUTS with a safety function to be reset by a soldering operation affecting operating value not fitted in ME EQUIPMENT as verified by examination of design and RISK MANAGEMENT FILE..... :	No temperature / overload control device	N/A
	c) An independent non-SELF-RESETTING THERMAL CUT-OUT is, additionally, provided where a failure of a THERMOSTAT could constitute a HAZARD as verified by examination of design and RISK MANAGEMENT FILE..... :	No temperature / overload control device	N/A
	d) Based on design and RISK MANAGEMENT FILE review, loss of function of ME EQUIPMENT due to operation of THERMAL CUT-OUT or OVER CURRENT RELEASE doesn't result in a HAZARDOUS SITUATION	No temperature / overload control device	N/A
	e) Capacitors or other spark-suppression devices not connected between contacts of THERMAL CUT-OUTS	No temperature / overload control device	N/A
	f) Use of THERMAL CUT-OUTS or OVER-CURRENT RELEASES do not affect safety of ME EQUIPMENT as verified by following tests:	No temperature / overload control device	N/A
	Positive temperature coefficient devices (PTC's) complied with IEC 60730-1: 1999, clauses 15, 17, J.15, and J.17 as applicable	No temperature / overload control device	N/A
	ME EQUIPMENT containing THERMAL CUT-OUTS and OVER-CURRENT RELEASES operated under the conditions of Clause 13	No temperature / overload control device	N/A
	SELF-RESETTING THERMAL CUT-OUTS and OVER-CURRENT RELEASES including circuits performing equivalent functions (other than PTC's) Certified according to appropriate standards ..	No temperature / overload control device	N/A
	In the absence of Certification in accordance with IEC standards, SELF-RESETTING THERMAL CUT-OUTS and OVER-CURRENT RELEASES including circuits performing equivalent functions (other than PTC's) operated 200 times	No temperature / overload control device	N/A
	Manual reset THERMAL CUT-OUTS and OVER-CURRENT RELEASES Certified in accordance with appropriate IEC standards	No temperature / overload control device	N/A
	When certification based on IEC standards, or data from MANUFACTURER demonstrating reliability of component to perform its safety-related function is not available, manual reset THERMAL CUT-OUTS and OVER-CURRENT RELEASES operated 10 times	No temperature / overload control device	N/A
	Thermal protective devices tested separately from ME EQUIPMENT when engineering judgment indicated test results would not be impacted	No temperature / overload control device	N/A

IEC 60601-1			
Clause	Requirement + Test	Result - Remark	Verdict
	g) Protective device, provided on ME EQUIPMENT incorporating a fluid filled container with heating means, operated when heater switched on with container empty and prevented an unacceptable RISK due to overheating	No temperature / overload control device	N/A
	h) ME EQUIPMENT with tubular heating elements provided with protection against overheating in both leads where a conductive connection to earth could result in overheating as verified by review of design and RISK MANAGEMENT FILE :	No temperature / overload control device	N/A
15.4.2.2	Temperature settings clearly indicated when means provided to vary setting of THERMOSTATS	No temperature / overload control device	N/A
15.4.3	Batteries		
15.4.3.1	Battery housings from which gases can escape during charging or discharging likely to result in a HAZARD ventilated to minimize RISK of accumulation and ignition as verified by review of design and RISK MANAGEMENT FILE :	No gas escape	N/A
	Battery compartments prevent accidental short circuiting of battery when this could result in a HAZARDOUS SITUATION as verified by examination of design and RISK MANAGEMENT FILE		P
15.4.3.2	Means provided to prevent incorrect connection of polarity when a HAZARDOUS SITUATION may develop by incorrect connection or replacement of a battery :	RMF check is not included in this evaluation	N/E
15.4.3.3	Overcharging of battery prevented by virtue of design when it could result in an unacceptable RISK as verified by review of design :	No charging mode for battery	N/A
15.4.3.4	Lithium batteries that could become a HAZARD complied with appropriate tests of IEC 60086-4	Battery is not included in this evaluation	N/E
	Tests of IEC 60086-4 waived on the lithium battery based on examination of design	Battery is not included in this evaluation	N/E
15.4.3.5	A properly RATED protective device provided within INTERNAL ELECTRICAL POWER SOURCE to protect against fire caused by excessive currents when (in case of a short circuit) layout of internal wiring, cross-sectional area, rating of connected components can result in a fire :	Battery is not included in this evaluation	N/E
	Protective device has adequate breaking capacity to interrupt the maximum fault current		P
	Justification for OVER-CURRENT RELEASES or FUSE exclusion is included in RISK MANAGEMENT FILE	RMF check is not included in this evaluation	N/E
15.4.4	Indicator lights provided to indicate ME EQUIPMENT is ready for NORMAL USE, except when apparent to OPERATOR from normal operating position, and marking of 7.4.1 are insufficient for this purpose :	RMF check is not included in this evaluation	N/E

IEC 60601-1			
Clause	Requirement + Test	Result - Remark	Verdict
	An additional indicator light provided on ME EQUIPMENT with a stand-by state or a warm-up state exceeding 15 s, except when apparent to OPERATOR from normal operating position	No stand-by / warm-up state	N/A
	Indicator lights provided on ME EQUIPMENT incorporating non-luminous heaters to indicate heaters are operational when a HAZARDOUS SITUATION could exist, except when apparent to OPERATOR from normal operating position	No heater	N/A
	Requirement not applied to heated stylus-pens for recording purposes	No heater	N/A
	Indicator lights provided on ME EQUIPMENT to indicate an output exists where an accidental or prolonged operation of output circuit could constitute a HAZARDOUS SITUATION	No output	N/A
	Colours of indicator lights complied with 7.8.1		P
	Charging mode visibly indicated in ME EQUIPMENT incorporating a means for charging an INTERNAL ELECTRICAL POWER SOURCE	No charging mode	N/A
15.4.5	RISKS associated with pre-set controls addressed in RISK MANAGEMENT PROCESS when applicable as verified by review of RISK MANAGEMENT FILE..... :	RMF check is not included in this evaluation	N/E
15.4.6	Actuating parts of controls of ME EQUIPMENT		
15.4.6.1	a) Actuating parts cannot be pulled off or loosened up during NORMAL USE		P
	b) Indication of scales (e.g., "on" "off" positions, etc.) always corresponds to position of controls with adjustment that can result in a HAZARDOUS SITUATION for PATIENT or OPERATOR while ME EQUIPMENT is in use		P
	c) Incorrect connection of indicating device to relevant component prevented by adequate construction when it could be separated without use of a TOOL	No such connection	N/A
	When torque values per Table 30 applied between control knob and shaft of rotating controls for not less than 2 s, 10 times in each direction, knobs did not rotate	No control knob / rotating control	N/A
	Tests conducted by applying an axial force of 60 N for electrical components and 100 N for other components for 1 min when an axial pull was required in NORMAL USE with no unacceptable RISK	No axial pull required during normal use	N/A

IEC 60601-1			
Clause	Requirement + Test	Result - Remark	Verdict
15.4.6.2	Stops of adequate mechanical strength provided on rotating/ movable parts of controls of ME EQUIPMENT where necessary to prevent an unexpected change from max to min, or vice-versa, of the controlled parameter when this could cause a HAZARDOUS SITUATION	No such stop	N/A
	Torque values in Table 30 applied 10 times in each direction to rotating controls for 2 sec ... :	No such stop	N/A
	Application of an axial force of 60 N for electrical components and 100 N for other components to rotating or movable parts of controls for 1 min when an axial pull was required in NORMAL USE	No axial pull required during normal use	N/A
15.4.7	Cord-connected HAND-HELD and foot-operated control devices		
15.4.7.1	a) HAND-HELD control devices of ME EQUIPMENT complied with 15.3.4.1	No cord-connected hand-held / foot-operated control device	N/A
	b) Foot-operated control device supported an actuating force of 1350 N for 1 min applied over an area of 30 mm diameter in its position of NORMAL USE with no damage to device causing an unacceptable RISK.....	No cord-connected hand-held / foot-operated control device	N/A
15.4.7.2	Control device of HAND-HELD and foot-operated control devices turned in all possible abnormal positions and placed on a flat surface	No cord-connected hand-held / foot-operated control device	N/A
	No unacceptable RISK caused by changing control setting when accidentally placed in an abnormal position	No cord-connected hand-held / foot-operated control device	N/A
15.4.7.3	a) Foot-operated control device is at least IPX1 & complies with tests of IEC 60529 (IP Code) ... :	No cord-connected hand-held / foot-operated control device	N/A
	b) ENCLOSURE of foot operated control devices containing electrical circuits is at least IPX6 and complies with IEC 60529 if in NORMAL USE liquids are likely to be found (IP Code)	No cord-connected hand-held / foot-operated control device	N/A
	Probability of occurrence estimated as part of RISK MANAGEMENT PROCESS	No cord-connected hand-held / foot-operated control device	N/A
15.4.8	Aluminum wires less than 16 mm ² in cross-sectional area are not used	No Aluminum wire	N/A
15.4.9	a) Oil container in PORTABLE ME EQUIPMENT allows for expansion of oil and is adequately sealed to prevent loss of oil in any position	No oil container	N/A
	b) Oil containers in MOBILE ME EQUIPMENT sealed to prevent loss of oil during transport	No oil container	N/A
	A pressure-release device operating during NORMAL USE is, optionally, provided	No oil container	N/A

IEC 60601-1			
Clause	Requirement + Test	Result - Remark	Verdict
	c) Partially sealed oil-filled ME EQUIPMENT and its parts provided with means for checking the oil level to detect leakage	No oil container	N/A
	ME EQUIPMENT and technical description examined, and manual tests conducted to confirm compliance with above requirements	No oil container	N/A
15.5	MAINS SUPPLY TRANSFORMERS OF ME EQUIPMENT and transformers providing separation in accordance with 8.5		
15.5.1	Overheating		
15.5.1.1	Transformers of ME EQUIPMENT are protected against overheating in the event of short circuit or overload of output windings and comply with this Clause and tests of 15.5.1.2 – 3	No mains transformer	N/A
	During tests, windings did not open, no HAZARDOUS SITUATION occurred, and maximum temperatures of windings did not exceed values in Table 31	No mains transformer	N/A
	Dielectric strength test of 8.8.3 conducted on transformer after short circuit and overload tests	No mains transformer	N/A
15.5.1.2	Transformer output winding short circuited, and test continued until protective device operated or THERMAL STABILITY achieved	No mains transformer	N/A
	Short circuit applied directly across output windings for transformers not tested according to 5X frequency and 5X voltage test of 15.5.2	No mains transformer	N/A
15.5.1.3	Multiple overload tests conducted on windings with more than one protective device to evaluate worst-case NORMAL USE loading and protection	No mains transformer	N/A
15.5.2	Transformer windings provided with adequate insulation to prevent internal short-circuits that could cause overheating which could result in a HAZARDOUS SITUATION	No mains transformer	N/A
	Dielectric strength tests were conducted in accordance with requirements of this clause with no breakdown of insulation system and no detectable deterioration of transformer	No mains transformer	N/A
15.5.3	Transformers forming MEANS OF PROTECTION as required by 8.5 comply with IEC 61558-1:1997, Clause 5.12	No mains transformer	N/A
16	ME SYSTEMS		

IEC 60601-1			
Clause	Requirement + Test	Result - Remark	Verdict
16.1	After installation or subsequent modification, ME SYSTEM didn't result in an unacceptable RISK	EUT can be considered as part of ME system via nurse call connection But ME system check is not included in this evaluation	N/E
	Only HAZARDS arising from combining various equipment to form a ME SYSTEM considered	EUT can be considered as part of ME system via nurse call connection But ME system check is not included in this evaluation	N/E
	– ME SYSTEM provides the level of safety within the PATIENT ENVIRONMENT equivalent to ME EQUIPMENT complying with this standard	EUT can be considered as part of ME system via nurse call connection But ME system check is not included in this evaluation	N/E
	– ME SYSTEM provides the level of safety outside PATIENT ENVIRONMENT equivalent to equipment complying with their respective IEC or ISO safety standards	EUT can be considered as part of ME system via nurse call connection But ME system check is not included in this evaluation	N/E
	– tests performed in NORMAL CONDITION, except as specified	EUT can be considered as part of ME system via nurse call connection But ME system check is not included in this evaluation	N/E
	– tests performed under operating conditions specified by MANUFACTURER of ME SYSTEM	EUT can be considered as part of ME system via nurse call connection But ME system check is not included in this evaluation	N/E
	Safety tests previously conducted on individual equipment of ME SYSTEM according to relevant standards not repeated	EUT can be considered as part of ME system via nurse call connection But ME system check is not included in this evaluation	N/E
	RISK MANAGEMENT methods, optionally, used by MANUFACTURER of an ME SYSTEM reconfigurable by RESPONSIBLE ORGANIZATION or OPERATOR to determine configurations with highest RISKS and measures to ensure any configuration of ME SYSTEM will not present unacceptable RISKS	EUT can be considered as part of ME system via nurse call connection But ME system check is not included in this evaluation	N/E
	Non-ME EQUIPMENT used in ME SYSTEM complied with applicable IEC or ISO safety standards	EUT can be considered as part of ME system via nurse call connection But ME system check is not included in this evaluation	N/E

IEC 60601-1			
Clause	Requirement + Test	Result - Remark	Verdict
	Equipment relying only on BASIC INSULATION for protection against electric shock not used in ME SYSTEM	EUT can be considered as part of ME system via nurse call connection But ME system check is not included in this evaluation	N/E
16.2	ACCOMPANYING DOCUMENTS of an ME SYSTEM		
	Documents containing all data necessary for ME SYSTEM to be used as intended by MANUFACTURER including a contact address accompany ME SYSTEM or modified ME SYSTEM	EUT can be considered as part of ME system via nurse call connection But ME system check is not included in this evaluation	N/E
	ACCOMPANYING DOCUMENTS regarded as a part of ME SYSTEM	EUT can be considered as part of ME system via nurse call connection But ME system check is not included in this evaluation	N/E
	ACCOMPANYING DOCUMENTS are, optionally, provided in electronic format (e.g. electronic file format or CD ROM) and ME SYSTEM is capable of displaying or printing these documents	EUT can be considered as part of ME system via nurse call connection But ME system check is not included in this evaluation	N/E
	a) ACCOMPANYING DOCUMENTS provided for each item of ME EQUIPMENT supplied by MANUFACTURER	EUT can be considered as part of ME system via nurse call connection But ME system check is not included in this evaluation	N/E
	b) ACCOMPANYING DOCUMENTS provided for each item of non-ME EQUIPMENT supplied by MANUFACTURER	EUT can be considered as part of ME system via nurse call connection But ME system check is not included in this evaluation	N/E
	c) the required information is provided:	EUT can be considered as part of ME system via nurse call connection But ME system check is not included in this evaluation	N/E
	– specifications, instructions for use as intended by MANUFACTURER, and a list of all items forming the ME SYSTEM	EUT can be considered as part of ME system via nurse call connection But ME system check is not included in this evaluation	N/E
	– instructions for installation, assembly, and modification of ME SYSTEM to ensure continued compliance with this standard	EUT can be considered as part of ME system via nurse call connection But ME system check is not included in this evaluation	N/E

IEC 60601-1			
Clause	Requirement + Test	Result - Remark	Verdict
	– instructions for cleaning and, when applicable, disinfecting and sterilizing each item of equipment or equipment part forming part of the ME SYSTEM	EUT can be considered as part of ME system via nurse call connection But ME system check is not included in this evaluation	N/E
	– additional safety measures to be applied during installation of ME SYSTEM	EUT can be considered as part of ME system via nurse call connection But ME system check is not included in this evaluation	N/E
	– identification of parts of ME SYSTEM suitable for use within the PATIENT ENVIRONMENT	EUT can be considered as part of ME system via nurse call connection But ME system check is not included in this evaluation	N/E
	– additional measures to be applied during preventive maintenance	EUT can be considered as part of ME system via nurse call connection But ME system check is not included in this evaluation	N/E
	– a warning forbidding placement of MULTIPLE SOCKET-OUTLET, when provided and it is a separate item, on the floor	EUT can be considered as part of ME system via nurse call connection But ME system check is not included in this evaluation	N/E
	– a warning indicating an additional MULTIPLE SOCKET-OUTLET or extension cord not to be connected to ME SYSTEM	EUT can be considered as part of ME system via nurse call connection But ME system check is not included in this evaluation	N/E
	– a warning to connect only items that have been specified as part of ME SYSTEM or specified as being compatible with ME SYSTEM	EUT can be considered as part of ME system via nurse call connection But ME system check is not included in this evaluation	N/E
	– maximum permissible load for any MULTIPLE SOCKET-OUTLET(S) used with ME SYSTEM	EUT can be considered as part of ME system via nurse call connection But ME system check is not included in this evaluation	N/E
	– instructions indicating MULTIPLE SOCKET-OUTLETS provided with the ME SYSTEM to be used only for supplying power to equipment intended to form part of ME SYSTEM	EUT can be considered as part of ME system via nurse call connection But ME system check is not included in this evaluation	N/E

IEC 60601-1			
Clause	Requirement + Test	Result - Remark	Verdict
	– an explanation indicating RISKS of connecting non-ME EQUIPMENT supplied as a part of ME SYSTEM directly to wall outlet when non-ME EQUIPMENT is intended to be supplied via a MULTIPLE SOCKET-OUTLET with a separating transformer	EUT can be considered as part of ME system via nurse call connection But ME system check is not included in this evaluation	N/E
	– an explanation indicating RISKS of connecting any equipment supplied as a part of ME SYSTEM to MULTIPLE SOCKET-OUTLET	EUT can be considered as part of ME system via nurse call connection But ME system check is not included in this evaluation	N/E
	– permissible environmental conditions of use for ME SYSTEM including conditions for transport and storage	EUT can be considered as part of ME system via nurse call connection But ME system check is not included in this evaluation	N/E
	– instructions to OPERATOR not to, simultaneously, touch parts referred to in 16.4 and PATIENT	EUT can be considered as part of ME system via nurse call connection But ME system check is not included in this evaluation	N/E
	d) the following instructions provided for use by RESPONSIBLE ORGANIZATION:	EUT can be considered as part of ME system via nurse call connection But ME system check is not included in this evaluation	N/E
	– adjustment, cleaning, sterilization, and disinfection PROCEDURES	EUT can be considered as part of ME system via nurse call connection But ME system check is not included in this evaluation	N/E
	– assembly of ME SYSTEMS and modifications during actual service life shall be evaluated based on the requirements of this standard	EUT can be considered as part of ME system via nurse call connection But ME system check is not included in this evaluation	N/E
16.3	Instructions for use of ME EQUIPMENT intended to receive its power from other equipment in an ME SYSTEM, describe the other equipment to ensure compliance with these requirements	EUT can be considered as part of ME system via nurse call connection But ME system check is not included in this evaluation	N/E

IEC 60601-1			
Clause	Requirement + Test	Result - Remark	Verdict
16.4	Parts of non-ME EQUIPMENT in PATIENT ENVIRONMENT subject to contact by OPERATOR during maintenance, calibration, after removal of covers, connectors, etc., without use of a TOOL operated at a voltage \leq voltage in 8.4.2 c) supplied from a source separated from SUPPLY MAINS by two MEANS OF OPERATOR PROTECTION	EUT can be considered as part of ME system via nurse call connection But ME system check is not included in this evaluation	N/E
16.5	Safety measures incorporating a SEPARATION DEVICE applied when FUNCTIONAL CONNECTION between ME EQUIPMENT and other items of an ME SYSTEM or other systems can cause allowable values of LEAKAGE CURRENT to exceed	EUT can be considered as part of ME system via nurse call connection But ME system check is not included in this evaluation	N/E
	SEPARATION DEVICE has dielectric strength, CREEPAGE and CLEARANCES required for one MEANS OF OPERATOR PROTECTION appropriate for highest voltage occurring across SEPARATION DEVICE during a fault condition	EUT can be considered as part of ME system via nurse call connection But ME system check is not included in this evaluation	N/E
	WORKING VOLTAGE was highest voltage across SEPARATION DEVICE during a fault condition, but not less than MAXIMUM MAINS VOLTAGE (V)..... :	EUT can be considered as part of ME system via nurse call connection But ME system check is not included in this evaluation	N/E
16.6	LEAKAGE CURRENTS		
16.6.1	TOUCH CURRENT in NORMAL CONDITION, from or between parts of ME SYSTEM within the PATIENT ENVIRONMENT, did not exceed 100 Ma	EUT can be considered as part of ME system via nurse call connection But ME system check is not included in this evaluation	N/E
	TOUCH CURRENT did not exceed 500 Ma in event of interruption of any non-PERMANENTLY INSTALLED PROTECTIVE EARTH CONDUCTOR, from or between parts of ME SYSTEM within PATIENT ENVIRONMENT	EUT can be considered as part of ME system via nurse call connection But ME system check is not included in this evaluation	N/E
16.6.2	Current in PROTECTIVE EARTH CONDUCTOR of MULTIPLE SOCKET-OUTLET did not exceed 5 Ma... :	EUT can be considered as part of ME system via nurse call connection But ME system check is not included in this evaluation	N/E
16.6.3	PATIENT LEAKAGE CURRENT and total PATIENT LEAKAGE CURRENT of ME SYSTEM in NORMAL CONDITION did not exceed values specified for ME EQUIPMENT in Tables 3 and 4	EUT can be considered as part of ME system via nurse call connection But ME system check is not included in this evaluation	N/E

IEC 60601-1			
Clause	Requirement + Test	Result - Remark	Verdict
	Measurements made using a device as in clause 8.7.4.4	EUT can be considered as part of ME system via nurse call connection But ME system check is not included in this evaluation	N/E
16.7	ME SYSTEM complied with applicable requirements of Clause 9 when a MECHANICAL HAZARD existed	EUT can be considered as part of ME system via nurse call connection But ME system check is not included in this evaluation	N/E
16.8	Interruption and restoration of relevant power connections of ME SYSTEM one at a time and all connections simultaneously did not result in a HAZARDOUS SITUATION other than interruption of its intended function	EUT can be considered as part of ME system via nurse call connection But ME system check is not included in this evaluation	N/E
16.9	ME SYSTEM connections and wiring		
16.9.1	Incorrect connection of accessible connectors, removable without a TOOL, prevented where a HAZARDOUS SITUATION could otherwise exist	EUT can be considered as part of ME system via nurse call connection But ME system check is not included in this evaluation	N/E
	– Connectors complied with Clause 15.4.1	EUT can be considered as part of ME system via nurse call connection But ME system check is not included in this evaluation	N/E
	– Plugs for connection of PATIENT leads could not be connected to other outlets of the same ME SYSTEM likely to be located in PATIENT ENVIRONMENT, except when examination of connectors and interchanging them proved no HAZARDOUS SITUATION could result	EUT can be considered as part of ME system via nurse call connection But ME system check is not included in this evaluation	N/E
16.9.2	MAINS PARTS, components and layout	EUT can be considered as part of ME system via nurse call connection But ME system check is not included in this evaluation	N/E
16.9.2.1	a) – MULTIPLE SOCKET-OUTLET only allows connection using a TOOL, or	EUT can be considered as part of ME system via nurse call connection But ME system check is not included in this evaluation	N/E

IEC 60601-1			
Clause	Requirement + Test	Result - Remark	Verdict
	– MULTIPLE SOCKET-OUTLET is of a type that cannot accept MAINS PLUGS of any of the kinds specified in IEC/TR 60083, or	EUT can be considered as part of ME system via nurse call connection But ME system check is not included in this evaluation	N/E
	– MULTIPLE SOCKET-OUTLET is supplied via a separating transformer	EUT can be considered as part of ME system via nurse call connection But ME system check is not included in this evaluation	N/E
	b) – MULTIPLE SOCKET-OUTLET marked with safety sign 2 of Table D.2 (i.e., safety sign ISO 7010-W001) visible in NORMAL USE, and	EUT can be considered as part of ME system via nurse call connection But ME system check is not included in this evaluation	N/E
	– marked either individually or in combinations, with the maximum allowed continuous output in amperes or volt-amperes, or	EUT can be considered as part of ME system via nurse call connection But ME system check is not included in this evaluation	N/E
	– marked to indicate the equipment or equipment parts it may safely be attached to	EUT can be considered as part of ME system via nurse call connection But ME system check is not included in this evaluation	N/E
	– MULTIPLE SOCKET-OUTLET is a separate item or an integral part of ME EQUIPMENT or non-ME EQUIPMENT	EUT can be considered as part of ME system via nurse call connection But ME system check is not included in this evaluation	N/E
	c) MULTIPLE SOCKET-OUTLET complied with IEC 60884-1 and the following requirements:	EUT can be considered as part of ME system via nurse call connection But ME system check is not included in this evaluation	N/E
	– CREEPAGE and CLEARANCES complied with 8.9	EUT can be considered as part of ME system via nurse call connection But ME system check is not included in this evaluation	N/E
	– It is CLASS I, and PROTECTIVE EARTH CONDUCTOR is connected to earthing contacts in socket-outlets	EUT can be considered as part of ME system via nurse call connection But ME system check is not included in this evaluation	N/E

IEC 60601-1			
Clause	Requirement + Test	Result - Remark	Verdict
	– PROTECTIVE EARTH TERMINALS and PROTECTIVE EARTH CONNECTIONS comply with 8.6, except total impedance for ME SYSTEM was up to 400 mΩ, or higher when conditions of 8.6.4 b) met (mΩ).. :	EUT can be considered as part of ME system via nurse call connection But ME system check is not included in this evaluation	N/E
	– ENCLOSURE complied with 8.4.2 d)	EUT can be considered as part of ME system via nurse call connection But ME system check is not included in this evaluation	N/E
	– MAINS TERMINAL DEVICES and wiring complied with 8.11.4, when applicable	EUT can be considered as part of ME system via nurse call connection But ME system check is not included in this evaluation	N/E
	– RATINGS of components are not in conflict with conditions of use	EUT can be considered as part of ME system via nurse call connection But ME system check is not included in this evaluation	N/E
	– Electrical terminals and connectors of MULTIPLE SOCKET-OUTLETS prevent incorrect connection of accessible connectors removable without a TOOL	EUT can be considered as part of ME system via nurse call connection But ME system check is not included in this evaluation	N/E
	– POWER SUPPLY CORD complied with 8.11.3	EUT can be considered as part of ME system via nurse call connection But ME system check is not included in this evaluation	N/E
	d) Additional requirements applied when MULTIPLE SOCKET-OUTLET combined with a separating transformer:	EUT can be considered as part of ME system via nurse call connection But ME system check is not included in this evaluation	N/E
	– Separating transformer complied with IEC 61558-2-1, except requirements of maximum RATED output power of 1 Kva and degree of protection IPX4 were not applied	EUT can be considered as part of ME system via nurse call connection But ME system check is not included in this evaluation	N/E
	– Separating transformer is CLASS I	EUT can be considered as part of ME system via nurse call connection But ME system check is not included in this evaluation	N/E

IEC 60601-1			
Clause	Requirement + Test	Result - Remark	Verdict
	– Degree of protection against ingress of water specified as in IEC 60529	EUT can be considered as part of ME system via nurse call connection But ME system check is not included in this evaluation	N/E
	– Separating transformer assembly marked according to 7.2 and 7.3	EUT can be considered as part of ME system via nurse call connection But ME system check is not included in this evaluation	N/E
	– MULTIPLE SOCKET-OUTLET permanently connected to separating transformer, or socket-outlet of separating transformer assembly cannot accept MAINS PLUGS as identified in IEC/TR 60083	EUT can be considered as part of ME system via nurse call connection But ME system check is not included in this evaluation	N/E
16.9.2.2	Removal of any single item of equipment in ME SYSTEM will not interrupt the protective earthing of any other part without simultaneous disconnection of electrical supply to that part	EUT can be considered as part of ME system via nurse call connection But ME system check is not included in this evaluation	N/E
	Additional PROTECTIVE EARTH CONDUCTORS can be detachable only by use of a TOOL	EUT can be considered as part of ME system via nurse call connection But ME system check is not included in this evaluation	N/E
16.9.2.3	Conductors connecting different items within an ME SYSTEM protected against mechanical damage	EUT can be considered as part of ME system via nurse call connection But ME system check is not included in this evaluation	N/E

17	ELECTROMAGNETIC COMPATIBILITY OF ME EQUIPMENT AND ME SYSTEMS		
	RISKS associated with items addressed in RISK MANAGEMENT PROCESS as confirmed by review . :	See report SH11071330-001	--
	– electromagnetic phenomena at locations where ME EQUIPMENT or ME SYSTEM is to be used as stated in ACCOMPANYING DOCUMENTS	See report SH11071330-001	--
	– introduction of electromagnetic phenomena into environment by ME EQUIPMENT or ME SYSTEM that might degrade performance of other devices, electrical equipment, and systems	See report SH11071330-001	--

ANNEX G	PROTECTION AGAINST HAZARDS OF IGNITION OF FLAMMABLE ANESTHETIC MIXTURES	
----------------	--	--

IEC 60601-1			
Clause	Requirement + Test	Result - Remark	Verdict
G.2	Locations and basic requirements		
G.2.1	Parts of CATEGORY APG ME EQUIPMENT in which a FLAMMABLE ANESTHETIC MIXTURE WITH AIR occurs are CATEGORY AP or APG ME EQUIPMENT and complied with G.3, G.4, and G.5	Not to be used with flammable anaesthetic mixture	N/A
G.2.2	FLAMMABLE AESTHETIC MIXTURE WITH AIR occurring due to a leakage or discharge of a FLAMMABLE AESTHETIC MIXTURE WITH OXYGEN or NITROUS OXIDE from an ENCLOSURE considered 5 to 25 cm from point of occurrence	Not to be used with flammable anaesthetic mixture	N/A
G.2.3	A FLAMMABLE AESTHETIC MIXTURE WITH OXYGEN or NITROUS OXIDE contained in a completely / partly enclosed ME EQUIPMENT part and in PATIENT'S respiratory tract 5 cm from an ENCLOSURE part where leakage or discharge occurs	Not to be used with flammable anaesthetic mixture	N/A
G.2.4	ME EQUIPMENT or parts thereof specified for use with FLAMMABLE AESTHETIC MIXTURE WITH AIR (in a location as in G.2.2) are CATEGORY AP or APG ME EQUIPMENT and complied with G.4 and G.5	Not to be used with flammable anaesthetic mixture	N/A
G.2.5	ME EQUIPMENT or parts thereof for use with FLAMMABLE AESTHETIC MIXTURE WITH OXYGEN OR NITROUS OXIDE (location per G.2.2) are CATEGORY APG ME EQUIPMENT and comply with G.4 and G.6	Not to be used with flammable anaesthetic mixture	N/A
	ME EQUIPMENT in G.2.3 to G.2.5 met appropriate tests of G.3-G.5 conducted after tests of 11.6.6 and 11.6.7	Not to be used with flammable anaesthetic mixture	N/A
G.3	Marking, ACCOMPANYING DOCUMENTS		
G.3.1	CATEGORY APG ME EQUIPMENT prominently marked. With a green-coloured band ≥ 2 cm wide with letters "APG" according to symbol 23 in Table D.1..... :	Not to be used with flammable anaesthetic mixture	N/A
	Length of green-coloured band is ≥ 4 cm, and size of marking is as large as possible for particular case	Not to be used with flammable anaesthetic mixture	N/A
	When above marking not possible, relevant information included in instructions for use ... :	Not to be used with flammable anaesthetic mixture	N/A
	Marking complied with tests and criteria of 7.1.2 and 7.1.3	Not to be used with flammable anaesthetic mixture	N/A
G.3.2	CATEGORY AP ME EQUIPMENT prominently marked, with a green-coloured circle ≥ 2 cm in diameter, with characters "AP" according to symbol 22 in Table D.1..... :	Not to be used with flammable anaesthetic mixture	N/A
	Marking is as large as possible for the particular case	Not to be used with flammable anaesthetic mixture	N/A

IEC 60601-1			
Clause	Requirement + Test	Result - Remark	Verdict
	When above marking not possible, the relevant information included in instructions for use ... :	Not to be used with flammable anaesthetic mixture	N/A
	Marking complied with tests and criteria of 7.1.2 and 7.1.3	Not to be used with flammable anaesthetic mixture	N/A
G.3.3	The marking according to G.3.2 and G.3.3 placed on major part of ME EQUIPMENT for CATEGORY AP or APG parts, and not repeated on detachable parts that can only be used with the marked EQUIPMENT	Not to be used with flammable anaesthetic mixture	N/A
G.3.4	ACCOMPANYING DOCUMENTS contain an indication enabling the RESPONSIBLE ORGANIZATION to distinguish between CATEGORY AP and APG parts	Not to be used with flammable anaesthetic mixture	N/A
G.3.5	Marking clearly indicates which parts are CATEGORY AP or APG when only certain ME EQUIPMENT parts are CATEGORY AP or APG	Not to be used with flammable anaesthetic mixture	N/A
G.4	Common requirements for CATEGORY AP and CATEGORY APG ME EQUIPMENT		
G.4.1	a) CREEPAGE and CLEARANCES between points of POWER SUPPLY CORD connection are according to Table 12 for one MEANS OF PATIENT PROTECTION	Not to be used with flammable anaesthetic mixture	N/A
	b) Connections, except those in circuits described in G.5.3 and G.6.3, protected against accidental disconnection in NORMAL USE or connection and disconnection can be performed only with a TOOL	Not to be used with flammable anaesthetic mixture	N/A
	c) CATEGORY AP and APG not provided with a DETACHABLE POWER SUPPLY CORD, except when circuit complied with G.5.3 and G.6.3	Not to be used with flammable anaesthetic mixture	N/A
G.4.2	Construction details		
	a) Opening of an ENCLOSURE providing protection against penetration of gases or vapours into ME EQUIPMENT or its parts possible only with a TOOL	Not to be used with flammable anaesthetic mixture	N/A
	b) ENCLOSURE complies with requirements to minimize arcing and sparking due to penetration of foreign objects..... :	Not to be used with flammable anaesthetic mixture	N/A
	– no openings on top covers of ENCLOSURE, except for openings for controls covered by control knobs	Not to be used with flammable anaesthetic mixture	N/A
	– openings in side-covers prevented penetration of a solid cylindrical test rod of 4 mm in diameter applied in all possible directions without appreciable force	Not to be used with flammable anaesthetic mixture	N/A

IEC 60601-1			
Clause	Requirement + Test	Result - Remark	Verdict
	– openings in base plates prevented penetration of a solid cylindrical test rod of 12 mm in diameter applied in all directions without appreciable force	Not to be used with flammable anaesthetic mixture	N/A
	c) Short circuiting conductor(s) to a conductive part without presence of explosive gasses where insulation may contact a part containing a FLAMMABLE AESTHETIC MIXTURE WITH OXYGEN or NITROUS OXIDE, ignitable gases alone, or oxygen, did not result in loss of integrity of the part, an unacceptable temperature, or other HAZARD	Not to be used with flammable anaesthetic mixture	N/A
G.4.3	a) Electrostatic charges prevented on CATEGORY AP and APG ME EQUIPMENT by a combination of appropriate measures	Not to be used with flammable anaesthetic mixture	N/A
	– Use of antistatic materials with a limited electrical resistance as specified in G.4.3 b) ... :	Not to be used with flammable anaesthetic mixture	N/A
	– Provision of electrically conductive paths from ME EQUIPMENT or its parts to a conductive floor, protective earth or potential equalization system, or via wheels to an antistatic floor of medical room	Not to be used with flammable anaesthetic mixture	N/A
	b) Electrical resistance limits of aesthetic tubing, mattresses and pads, castor tires, and other antistatic material complied with ISO 2882 based on measurements according to ISO 1853, ISO 2878 and ISO 23529..... :	Not to be used with flammable anaesthetic mixture	N/A
G.4.4	Corona cannot be produced by components or parts of ME EQUIPMENT operating at more than 2000 V a.c. or 2400 V d.c. and not included in ENCLOSURES complying with G.5.4 or G.5.5	Not to be used with flammable anaesthetic mixture	N/A
G.5	Requirements and tests for CATEGORY AP ME EQUIPMENT, parts and components		
G.5.1	ME EQUIPMENT, its parts or components do not ignite FLAMMABLE AESTHETIC MIXTURES WITH AIR under NORMAL USE and CONDITIONS based on compliance with G.5.2 to G.5.5 (inclusive)	Not to be used with flammable anaesthetic mixture	N/A
	Alternatively, ME EQUIPMENT, its parts, and components complied with requirements of IEC 60079-0 for pressurized ENCLOSURES (IEC 60079-2); for sand-filled ENCLOSURES, IEC 60079-5; or for oil immersed equipment, IEC 60079-6; and with this standard excluding G.5.2 to G.5.5..... :	Not to be used with flammable anaesthetic mixture	N/A
G.5.2	ME EQUIPMENT, its parts, and components in contact with gas mixtures in NORMAL USE and CONDITIONS not producing sparks and not resulting in surface temperatures above 150 °C in case of restricted or 200 °C in case of unrestricted vertical air circulation measured at 25 °C comply with G.5.1..... :	Not to be used with flammable anaesthetic mixture	N/A

IEC 60601-1			
Clause	Requirement + Test	Result - Remark	Verdict
G.5.3	ME EQUIPMENT, its parts, and components producing sparks in NORMAL USE and CONDITION complied with temperature requirements of G.5.2, and U_{max} and I_{max} occurring in their circuits, and complied as follows:	Not to be used with flammable anaesthetic mixture	N/A
	Measured $U_{max} \leq U_{Zr}$ with I_{Zr} as in Fig. G.1..... :	Not to be used with flammable anaesthetic mixture	N/A
	Measured $U_{max} \leq U_c$ with C_{max} as in Fig. G.2 ... :	Not to be used with flammable anaesthetic mixture	N/A
	Measured $I_{max} \leq I_{Zr}$ with U_{Zr} as in Fig G.1 :	Not to be used with flammable anaesthetic mixture	N/A
	Measured $I_{max} \leq I_{Zl}$ with L_{max} and a $U_{max} \leq 24 V$ as in Fig G.3 :	Not to be used with flammable anaesthetic mixture	N/A
	– Combinations of currents and corresponding voltages within the limitations $I_{Zr} \cdot U_{Zr} \leq 50 W$ extrapolated from Fig G.1	Not to be used with flammable anaesthetic mixture	N/A
	No extrapolation made for voltages above 42 V	Not to be used with flammable anaesthetic mixture	N/A
	– Combinations of capacitances and corresponding voltages within limitations of $C/2U^2 \leq 1.2 Mj$ extrapolated from Fig G.2	Not to be used with flammable anaesthetic mixture	N/A
	No extrapolation made for voltages above 242V	Not to be used with flammable anaesthetic mixture	N/A
	U_{max} , additionally, determined using actual resistance R when the equivalent resistance R was less than 8000 Ω	Not to be used with flammable anaesthetic mixture	N/A
	– Combinations of currents and corresponding inductances within limitations $L/2I^2 \leq 0.3 Mj$ extrapolated from Fig G.3	Not to be used with flammable anaesthetic mixture	N/A
	No extrapolation made for inductances larger than 900 Mh	Not to be used with flammable anaesthetic mixture	N/A
	– U_{max} was the highest supply voltage occurring in circuit under investigation with sparking contact open, taking into consideration MAINS VOLTAGE variations in 4.10	Not to be used with flammable anaesthetic mixture	N/A
	– I_{max} was the highest current flowing in circuit under investigation with sparking contact closed, taking into consideration MAINS VOLTAGE variations required in 4.10	Not to be used with flammable anaesthetic mixture	N/A

IEC 60601-1			
Clause	Requirement + Test	Result - Remark	Verdict
	– C_{max} and L_{max} taken as values occurring at the component under investigation producing sparks	Not to be used with flammable anaesthetic mixture	N/A
	– Peak value considered when a.c. supplied	Not to be used with flammable anaesthetic mixture	N/A
	– An equivalent circuit calculated to determine equivalent max capacitance, inductance, and equivalent U_{max} and I_{max} , either as d.c. or a.c. peak values in case of a complicated circuit... :	Not to be used with flammable anaesthetic mixture	N/A
	Temperature measurements made according to 11.1, and U_{max} , I_{max} , R , L_{max} , and C_{max} determined with application of Figs G.1-G.3 .. :	Not to be used with flammable anaesthetic mixture	N/A
	Alternatively, compliance was verified by examination of design data	Not to be used with flammable anaesthetic mixture	N/A
G.5.4	External ventilation with internal overpressure		
	ME EQUIPMENT, its parts, and components enclosed in an ENCLOSURE with external ventilation by means of internal overpressure complied with the following requirements:	Not to be used with flammable anaesthetic mixture	N/A
	a) FLAMMABLE AESTHETIC MIXTURES WITH AIR that might have penetrated into ENCLOSURE of ME EQUIPMENT or part removed by ventilation before EQUIPMENT energized, and penetration of such mixtures during operation was prevented by maintenance of overpressure by means of air without flammable gases, or by physiologically acceptable inert gas (e.g., nitrogen)	Not to be used with flammable anaesthetic mixture	N/A
	b) Overpressure inside ENCLOSURE was 75 Pa, min., in NORMAL CONDITION (Pa)..... :	Not to be used with flammable anaesthetic mixture	N/A
	Overpressure maintained at the site of potential ignition even when air or inert gas could escape through openings in ENCLOSURE necessary for normal operation of ME EQUIPMENT or its parts	Not to be used with flammable anaesthetic mixture	N/A
	ME EQUIPMENT could be energized only after the required minimum overpressure was present long enough to ventilate the ENCLOSURE so that the displaced volume of air or inert gas was at least five times the volume of ENCLOSURE	Not to be used with flammable anaesthetic mixture	N/A
	ME EQUIPMENT energized at will or repeatedly when overpressure was continuously present	Not to be used with flammable anaesthetic mixture	N/A

IEC 60601-1			
Clause	Requirement + Test	Result - Remark	Verdict
	c) Ignition sources de-energized automatically by means used where G.4 does not apply, or complied with G.5 when during operation overpressure dropped below 50 Pa (Pa)..... :	Not to be used with flammable anaesthetic mixture	N/A
	d) External surface of ENCLOSURE in which internal overpressure was maintained did not exceed 150 °C in 25 °C ambient under NORMAL USE and CONDITION (°C)..... :	Not to be used with flammable anaesthetic mixture	N/A
G.5.5	ENCLOSURES with restricted breathing		
	ME EQUIPMENT, its parts, and components enclosed in an ENCLOSURE with restricted breathing complied with the following:	Not to be used with flammable anaesthetic mixture	N/A
	a) A FLAMMABLE AESTHETIC MIXTURE WITH AIR did not form inside ENCLOSURE with restricted breathing when it was surrounded by a FLAMMABLE AESTHETIC MIXTURE WITH AIR of a high concentration for at least 30 min without any pressure difference inside ENCLOSURE	Not to be used with flammable anaesthetic mixture	N/A
	b) Gasket or sealing material used to maintain tightness complied with aging test B-b of IEC 60068-2-2, Clause 15, at 70 °C ± 2 °C and 96 h :	Not to be used with flammable anaesthetic mixture	N/A
	c) Gas-tightness of ENCLOSURE containing inlets for flexible cords maintained when the cords were stressed by bending or pulling	Not to be used with flammable anaesthetic mixture	N/A
	Cords are fitted with adequate anchorages to limit stresses	Not to be used with flammable anaesthetic mixture	N/A
	After the test in G.5.4 b), an internal overpressure of 400 Pa was created and 30 pulls of the value in Table G.1 applied to each flexible cord in axial direction of cord inlet and in the least favourable direction for 1 s	Not to be used with flammable anaesthetic mixture	N/A
	Overpressure not reduced below 200 Pa	Not to be used with flammable anaesthetic mixture	N/A
	Tests waived when examination of ENCLOSURE indicated it is completely sealed or gas-tight without a doubt (100 % degree of certainty)	Not to be used with flammable anaesthetic mixture	N/A
	Operating temperature of external surface of ENCLOSURE was ≤ 150 °C in 25 °C (°C)..... :	Not to be used with flammable anaesthetic mixture	N/A
	Steady state operating temperature of ENCLOSURE also measured (°C)..... :	Not to be used with flammable anaesthetic mixture	N/A
G.6	CATEGORY APG ME EQUIPMENT, parts and components thereof		

IEC 60601-1			
Clause	Requirement + Test	Result - Remark	Verdict
G.6.1	ME EQUIPMENT, its parts, and components did not ignite FLAMMABLE AESTHETIC MIXTURE WITH OXYGEN OR NITROUS OXIDE under NORMAL USE and SINGLE FAULT CONDITION	Not to be used with flammable anaesthetic mixture	N/A
	ME EQUIPMENT, its parts, and components not complying with G.6.3 subjected to a CONTINUOUS OPERATION test after attaining thermal steady state (max. 3 h) over a period of 10 min in a 12.2 % ± 0.4 ether by volume/oxygen mixture	Not to be used with flammable anaesthetic mixture	N/A
G.6.2	Parts and components of CATEGORY APG ME EQUIPMENT operating in a FLAMMABLE AESTHETIC MIXTURE WITH OXYGEN OR NITROUS OXIDE supplied from a source isolated from earth by insulation equal to one MEANS OF PATIENT PROTECTION and from electrical parts by insulation twice the MEANS OF PATIENT PROTECTION..... :	Not to be used with flammable anaesthetic mixture	N/A
G.6.3	Test of G.6.1 waived when the following requirements were met in NORMAL USE and under NORMAL and SINGLE FAULT CONDITIONS..... :	Not to be used with flammable anaesthetic mixture	N/A
	a) no sparks produced and temperatures did not exceed 90 °C, or	Not to be used with flammable anaesthetic mixture	N/A
	b) a temperature limit of 90 °C not exceeded, sparks produced in NORMAL USE, and SINGLE FAULT CONDITIONS, except U_{max} and I_{max} occurring in their circuits complied with requirements, taking C_{max} and L_{max} into consideration:	Not to be used with flammable anaesthetic mixture	N/A
	Measured $U_{max} \leq U_{Zr}$ with I_{Zr} as in Fig. G.4 :	Not to be used with flammable anaesthetic mixture	N/A
	Measured $U_{max} \leq U_{ZC}$ with C_{max} as in Fig. G.5 .. :	Not to be used with flammable anaesthetic mixture	N/A
	Measured $I_{max} \leq I_{Zr}$ with U_{Zr} as in Fig G.4 :	Not to be used with flammable anaesthetic mixture	N/A
	Measured $I_{max} \leq I_{Zl}$ with L_{max} and a $U_{max} \leq 24$ V as in Fig G.6 :	Not to be used with flammable anaesthetic mixture	N/A
	– Extrapolation from Figs G.4, G.5, and G.6 was limited to areas indicated	Not to be used with flammable anaesthetic mixture	N/A
	– U_{max} was the highest no-load voltage occurring in the circuit under investigation, taking into consideration mains voltage variations as in 4.10	Not to be used with flammable anaesthetic mixture	N/A

IEC 60601-1			
Clause	Requirement + Test	Result - Remark	Verdict
	– I_{max} was the highest current flowing in the circuit under investigation, taking into account MAINS VOLTAGE variations as in 4.10	Not to be used with flammable anaesthetic mixture	N/A
	– C_{max} and L_{max} are values occurring in relevant circuit	Not to be used with flammable anaesthetic mixture	N/A
	– U_{max} additionally determined with actual resistance R when equivalent resistance R in Fig G.5 was less than 8000 Ω	Not to be used with flammable anaesthetic mixture	N/A
	– Peak value taken into consideration when a.c. supplied	Not to be used with flammable anaesthetic mixture	N/A
	– An equivalent circuit calculated to determine max capacitance, inductance, and U_{max} and I_{max} , either as d.c. or a.c. peak values in case of a complicated circuit	Not to be used with flammable anaesthetic mixture	N/A
	– When energy produced in an inductance or capacitance in a circuit is limited by voltage or current-limiting devices, two independent components applied, to obtain the required limitation even when a first fault (short or open circuit) in one of these components	Not to be used with flammable anaesthetic mixture	N/A
	Above requirement not applied to transformers complying with this standard	Not to be used with flammable anaesthetic mixture	N/A
	Above requirement not applied to wire-wound current-limiting resistors provided with a protection against unwinding of the wire in case of rupture	Not to be used with flammable anaesthetic mixture	N/A
	Compliance verified by examination of CATEGORY APG ME EQUIPMENT, parts, and components , or	Not to be used with flammable anaesthetic mixture	N/A
	Temperature measurements made in accordance with 11.1, or	Not to be used with flammable anaesthetic mixture	N/A
	U_{max} , I_{max} , R, L_{max} and C_{max} determined together with application of Figs G.4-G.6..... :	Not to be used with flammable anaesthetic mixture	N/A
	Alternatively, compliance verified by comparison with design data	Not to be used with flammable anaesthetic mixture	N/A
G.6.4	ME EQUIPMENT, its parts, and components heating a FLAMMABLE AESTHETIC MIXTURE WITH OXYGEN OR NITROUS OXIDE provided with a non-SELF-RESETTING THERMAL CUT-OUT and complied with 15.4.2.1..... :	Not to be used with flammable anaesthetic mixture	N/A

IEC 60601-1			
Clause	Requirement + Test	Result - Remark	Verdict
	Current-carrying part of heating element is not in direct contact with FLAMMABLE AESTHETIC MIXTURE WITH OXYGEN OR NITROUS OXIDE	Not to be used with flammable anaesthetic mixture	N/A
G.7	Test apparatus for flammable mixtures		
	Test apparatus used was in accordance with this Clause and Fig G.7	Not to be used with flammable anaesthetic mixture	N/A

ANNEX L	INSULATED WINDING WIRES FOR USE WITHOUT INTERLEAVED INSULATION		
L.1	BASIC, SUPPLEMENTARY, DOUBLE, and REINFORCED INSULATION in wound components without interleaved insulation complied with this Annex covering round winding wires between 0.05 mm and 5.00 mm diameters	No insulated winding wires for use without interleaved insulation	N/A
L.2	Wire construction		
	Overlap of layers when wire is insulated with two or more spirally wrapped layers of tape is adequate to ensure continued overlap during manufacture of wound component	No insulated winding wires for use without interleaved insulation	N/A
	Layers of spirally wrapped wire insulation are sufficiently secured to maintain the overlap	No insulated winding wires for use without interleaved insulation	N/A
L.3	Type Test		
	The wire subjected to tests of L.3.1 to L.3.4 at a temperature and a relative humidity specified	No insulated winding wires for use without interleaved insulation	N/A
	Temperature (°C)..... :	No insulated winding wires for use without interleaved insulation	—
	Humidity (%)..... :	No insulated winding wires for use without interleaved insulation	—
L.3.1	Dielectric strength		
	Dielectric strength test of Clause 8.8.3 for the appropriate type and number of MOP(s) conducted by preparing the sample according to IEC 60851-5:1996, Clause 4.4.1 for a twisted pair with test voltages at least twice Tables 6 & 7, but not less than below with no breakdown:	No insulated winding wires for use without interleaved insulation	N/A
	– 3000 V for BASIC and SUPPLEMENTARY INSULATION (V)..... :	No insulated winding wires for use without interleaved insulation	N/A
	– 6000 V for REINFORCED INSULATION (V) :	No insulated winding wires for use without interleaved insulation	N/A

IEC 60601-1			
Clause	Requirement + Test	Result - Remark	Verdict
L.3.2	Flexibility and adherence		
	Sample subjected to flexibility and adherence test 8 of IEC 60851-3:1996, clause 5.1.1, using mandrel diameters of Table L.1	No insulated winding wires for use without interleaved insulation	N/A
	Sample examined according to IEC 60851-3: 1997, clause 5.1.1.4, followed by dielectric test of clause 8.8.3, except test voltage applied between wire and mandrel with no breakdown	No insulated winding wires for use without interleaved insulation	N/A
	Test voltage was at least the voltage in Tables 6 and 7 but not less than the following:	No insulated winding wires for use without interleaved insulation	N/A
	– 1500 V for BASIC and SUPPLEMENTARY INSULATION (V)..... :	No insulated winding wires for use without interleaved insulation	N/A
	– 3000 V for REINFORCED INSULATION (V) :	No insulated winding wires for use without interleaved insulation	N/A
	Tension applied to wire during winding on mandrel calculated from the wire diameter equivalent to 118 Mpa ± 11.8 Mpa :	No insulated winding wires for use without interleaved insulation	N/A
L.3.3	Heat Shock		
	Sample subjected to heat shock test 9 of IEC 60851-6:1996, followed by dielectric strength test of clause 8.8.3, except test voltage applied between the wire and mandrel	No insulated winding wires for use without interleaved insulation	N/A
	Test voltage was at least the voltage in Tables 6 and 7, but not less than the following:	No insulated winding wires for use without interleaved insulation	N/A
	– 1500 V for BASIC and SUPPLEMENTARY INSULATION (V)..... :	No insulated winding wires for use without interleaved insulation	N/A
	– 3000 V for REINFORCED INSULATION (V) :	No insulated winding wires for use without interleaved insulation	N/A
	Oven temperature based on Table L.2 (°C)..... :	No insulated winding wires for use without interleaved insulation	—
	Mandrel diameter and tension applied as in clause L.3.2, (Mpa; N/mm ²)..... :	No insulated winding wires for use without interleaved insulation	N/A
	Dielectric strength test conducted at room temperature after removal from the oven	No insulated winding wires for use without interleaved insulation	N/A
L.3.4	Retention of electric strength after bending		

IEC 60601-1			
Clause	Requirement + Test	Result - Remark	Verdict
	Five samples prepared as in L.3.2 subjected to dielectric strength and bending tests	No insulated winding wires for use without interleaved insulation	N/A
	Test voltage was at least the voltage in Tables 6 and 7, but not less than the following:	No insulated winding wires for use without interleaved insulation	N/A
	– 1500 V for BASIC and SUPPLEMENTARY INSULATION (V)..... :	No insulated winding wires for use without interleaved insulation	N/A
	– 3000 V for REINFORCED INSULATION (V) :	No insulated winding wires for use without interleaved insulation	N/A
	Test voltage applied between the shot and conductor.	No insulated winding wires for use without interleaved insulation	N/A
	Mandrel diameter and tension applied as in L.3.2, (Mpa; N/mm ²) :	No insulated winding wires for use without interleaved insulation	N/A
L.4	Tests during manufacture		
L.4.1	Production line dielectric strength tests conducted by the manufacture according to L.4.2 and L.4.3.....:	No insulated winding wires for use without interleaved insulation	N/A
L.4.2	Test voltage for routine testing (100 % testing) is at least the voltage in Tables 6 and 7 but not less than the following:	No insulated winding wires for use without interleaved insulation	N/A
	– 1500 V r.m.s. or 2100 V peak for BASIC and SUPPLEMENTARY INSULATION (V).....:	No insulated winding wires for use without interleaved insulation	N/A
	– 3000 V r.m.s. or 4200 V peak for REINFORCED INSULATION (V):	No insulated winding wires for use without interleaved insulation	N/A
L.4.3	Sampling tests conducted using twisted pair samples (IEC 60851-5:1996, clause 4.4.1)	No insulated winding wires for use without interleaved insulation	N/A
	Minimum breakdown test voltage at least twice the voltage in Tables 6 and 7 but not less than:	No insulated winding wires for use without interleaved insulation	N/A
	– 3000 V r.m.s. or 4200 V peak for BASIC and SUPPLEMENTARY INSULATION	No insulated winding wires for use without interleaved insulation	N/A
	– 6000 V r.m.s. or 8400 V peak for REINFORCED INSULATION	No insulated winding wires for use without interleaved insulation	N/A

IEC 60601-1			
Clause	Requirement + Test	Result - Remark	Verdict

4.2	RM RESULTS TABLE: Risk Management Process for ME Equipment or ME Systems		N/A
Clause of ISO 14971	Document Ref. in RMF (Document No. & paragraph)	Result – Remarks	Verdict
3.3a			
3.5e			
4.1			
4.2			
4.3			
4.4			
5			
6.1			
6.2			
6.3			
6.4			
6.5			
6.6			
6.7			
7			

4.3	TABLE: ESSENTIAL PERFORMANCE		N/A
List of ESSENTIAL PERFORMANCE functions	MANUFACTURER'S document number reference or reference from this standard or collateral or particular standard(s)	Remarks	

Supplementary Information:

ESSENTIAL PERFORMANCE is performance, the absence or degradation of which, would result in an unacceptable risk.

4.3	RM RESULTS TABLE: Essential Performance		N/A
Clause of ISO 14971	Document Ref. in RMF (Document No. & paragraph)	Result – Remarks	Verdict
4.2			
4.3			
4.4			
5			

IEC 60601-1			
Clause	Requirement + Test	Result - Remark	Verdict

4.5	RM RESULTS TABLE: Equivalent Safety for ME Equipment of ME System		N/A
Clause of ISO 14971	Document Ref. in RMF (Document No. & paragraph)	Result – Remarks	Verdict
4.2			
4.3			
4.4			
5			
6.2			
6.3			
6.4			
6.5			

4.6	RM RESULTS TABLE: ME Equipment or system parts contacting the patient		N/A
Clause of ISO 14971	Document Ref. in RMF (Document No. & paragraph)	Result – Remarks	Verdict
4.2			
4.3			
4.4			
5			
6.2			
6.3			
6.4			
6.5			

4.7	RM RESULTS TABLE: Single Fault Condition for ME Equipment		N/A
Clause of ISO 14971	Document Ref. in RMF (Document No. & paragraph)	Result – Remarks	Verdict
4.2			
4.3			
4.4			

4.8	RM RESULTS TABLE: Components of ME Equipment		N/A
Clause of ISO 14971	Document Ref. in RMF (Document No. & paragraph)	Result – Remarks	Verdict
4.2			
4.3			
4.4			
5			
6.2			
6.3			
6.4			
6.5			

IEC 60601-1			
Clause	Requirement + Test	Result - Remark	Verdict

4.9	RM RESULTS TABLE: Use of components with high-integrity characteristics		N/A
Clause of ISO 14971	Document Ref. in RMF (Document No. & paragraph)	Result – Remarks	Verdict
4.2			
4.3			
4.4			
5			
6.2			
6.3			
6.4			
6.5			

4.11	TABLE: Power Input					N/A
Operating Conditions / Ratings	Voltage (V)	Frequency (Hz)	Current (A)	Power (W or VA)	Power factor (cos ϕ)	

Supplementary Information:

5.1	RM RESULTS TABLE: Type Tests		N/A
Clause of ISO 14971	Document Ref. in RMF (Document No. & paragraph)	Result – Remarks	Verdict
4.2			
4.3			
4.4			

5.4 a)	RM RESULTS TABLE: Other Conditions		N/A
Clause of ISO 14971	Document Ref. in RMF (Document No. & paragraph)	Result – Remarks	Verdict
4.2			
4.3			
4.4			

IEC 60601-1			
Clause	Requirement + Test	Result - Remark	Verdict

5.7	RM RESULTS TABLE: Humidity preconditioning treatment		N/A
Clause of ISO 14971	Document Ref. in RMF (Document No. & paragraph)	Result – Remarks	Verdict
4.2			
4.3			
4.4			
5			
6.2			
6.3			
6.4			
6.5			

5.9.2	TABLE: Determination of ACCESSIBLE parts		P
Location	Determination method (NOTE1)	Comments	
Enclosure	Visual		
Supplementary information:			
NOTE 1 – The determination methods are: visual; rigid test finger; jointed test finger; test hook.			

5.9.2.3	RM RESULTS TABLE: Actuating mechanisms		N/A
Clause of ISO 14971	Document Ref. in RMF (Document No. & paragraph)	Result – Remarks	Verdict
4.2			
4.3			
4.4			
5			
6.2			
6.3			
6.4			
6.5			

IEC 60601-1			
Clause	Requirement + Test	Result - Remark	Verdict

7.1.2	TABLE: Legibility of Marking		P
Markings tested	Ambient illuminance (lx)	Remarks	
Outside Markings (Clause 7.2)	100-1500		
Inside Markings (Clause 7.3)			
Controls & Instruments (Clause 7.4)			
Safety Signs (Clause 7.5)			
Symbols (Clause 7.6)			
Supplementary information: Observer, with a visual acuity of 0 on the log Minimum Angle of Resolution (log MAR) scale or 6/6 (20/20), reads marking at ambient illuminance least favourable level in the range of 100 lx to 1,500 lx. The ME EQUIPMENT or its part was positioned so that the viewpoint was the intended position of the OPERATOR at any point within the base of a cone subtended by an angle of 30° to the axis normal to the centre of the plane of the marking and at a distance of 1 m.			

7.1.3	TABLE: Durability of marking test		P
Characteristics of the Marking Label tested:		Remarks	
Material of Marking Label	Silk print		
Ink/other printing material or process			
Material (composition) of Warning Label			
Ink/other printing material or process			
Other			
Supplementary information: Marking rubbed by hand, first for 15 s with a cloth rag soaked with distilled water, then for 15 s with a cloth rag soaked with methylated spirit, and then for 15 s with a cloth rag soaked with isopropyl alcohol.			

7.2.2	RM RESULTS TABLE: Identification		N/A
Clause of ISO 14971	Document Ref. in RMF (Document No. & paragraph)	Result – Remarks	Verdict
4.2			
4.3			
4.4			
5			
6.4			

IEC 60601-1			
Clause	Requirement + Test	Result - Remark	Verdict

7.2.5	RM RESULTS TABLE: ME EQUIPMENT powered from other equipment		N/A
Clause of ISO 14971	Document Ref. in RMF (Document No. & paragraph)	Result – Remarks	Verdict
4.2			
4.3			
4.4			
5			
6.4			

7.2.13	RM RESULTS TABLE: Physiological effects (safety signs and warning)		N/A
Clause of ISO 14971	Document Ref. in RMF (Document No. & paragraph)	Result – Remarks	Verdict
4.2			
4.3			
4.4			
5			
6.3			

7.2.17	RM RESULTS TABLE: Protective packaging		N/A
Clause of ISO 14971	Document Ref. in RMF (Document No. & paragraph)	Result - Remarks	Verdict
4.2			
4.3			
4.4			
5			
6.3			
6.4			

7.3.3	RM RESULTS TABLE: Batteries		N/A
Clause of ISO 14971	Document Ref. in RMF (Document No. & paragraph)	Result - Remarks	Verdict
4.2			
4.3			
4.4			
5			
6.3			

7.3.7	RM RESULTS TABLE: Supply terminals		N/A
Clause of ISO 14971	Document Ref. in RMF (Document No. & paragraph)	Result - Remarks	Verdict
4.3			

IEC 60601-1			
Clause	Requirement + Test	Result - Remark	Verdict

7.4.2	RM RESULTS TABLE: Control devices		N/A
Clause of ISO 14971	Document Ref. in RMF (Document No. & paragraph)	Result - Remarks	Verdict
4.2			
4.3			
4.4			
5			
6.2			
6.3			

7.5	RM RESULTS TABLE: Safety signs		N/A
Clause of ISO 14971	Document Ref. in RMF (Document No. & paragraph)	Result - Remarks	Verdict
4.2			
4.3			
4.4			
5			
6.3			

7.9.1	RM RESULTS TABLE: General accompanying documents (See Table C.4)		N/A
Clause of ISO 14971	Document Ref. in RMF (Document No. & paragraph)	Result - Remarks	Verdict
4.2			
4.3			
4.4			
5			
6.2			
6.3			

7.9.2.4	RM RESULTS TABLE: Electrical power source		N/A
Clause of ISO 14971	Document Ref. in RMF (Document No. & paragraph)	Result - Remarks	Verdict
4.2			
4.3			
4.4			
5			
6.3			

IEC 60601-1			
Clause	Requirement + Test	Result - Remark	Verdict

7.9.3.2	RM RESULTS TABLE: Replacement of fuses, power supply cords, other parts		N/A
Clause of ISO 14971	Document Ref. in RMF (Document No. & paragraph)	Result - Remarks	Verdict
4.2			
4.3			
4.4			
5			
6.2			
6.3			
6.4			
6.5			

8.1 b(1)	RM RESULTS TABLE: Fundamental rule of protection against electric shock - interruption of any one power-carrying conductor		N/A
Clause of ISO 14971	Document Ref. in RMF (Document No. & paragraph)	Result - Remarks	Verdict
4.3			
4.4			

8.1 b(2)	RM RESULTS TABLE: Fundamental rule of protection against electric shock - unintended movement of a component		N/A
Clause of ISO 14971	Document Ref. in RMF (Document No. & paragraph)	Result - Remarks	Verdict
4.2			
4.3			
4.4			
5			
6.2			
6.3			
6.4			
6.5			

8.1 b(3)	RM RESULTS TABLE: Fundamental rule of protection against electric shock - accidental detachment of conductors and connectors		N/A
Clause of ISO 14971	Document Ref. in RMF (Document No. & paragraph)	Result - Remarks	Verdict
4.3			

IEC 60601-1			
Clause	Requirement + Test	Result - Remark	Verdict

8.2.2	RM RESULTS TABLE: Connection to an external d.c. power sources		N/A
Clause of ISO 14971	Document Ref. in RMF (Document No. & paragraph)	Result - Remarks	Verdict
4.2			
4.3			
4.4			
5			

8.3 d	RM RESULTS TABLE: Requirements of Type BF or CF Applied Parts		N/A
Clause of ISO 14971	Document Ref. in RMF (Document No. & paragraph)	Result - Remarks	Verdict
6.2		See also RM Table for 4.6	

8.4.2	TABLE: TABLE: Working Voltage / Power Measurement					P
Location From/To	Measured values					Remarks
	Vrms	Vpk or Vdc	Peak-to-peak ripple ²	Power W/VA	Energy (J)	
Enclosure	--	--	--	--	--	
Supplementary Information:						
1. The input supply voltage to the ME EQUIPMENT shall be the RATED voltage or the voltage within the RATED voltage range which results in the highest measured value. See clause 8.5.4.						
2. If the d.c peak-to-peak ripple >10%, waveform considered as a.c. See clause 8.4.2.2						

8.4.2 c	RM RESULTS TABLE: Accessible parts including applied parts		N/A
Clause of ISO 14971	Document Ref. in RMF (Document No. & paragraph)	Result - Remarks	Verdict
4.2			
4.3			
4.4			

IEC 60601-1			
Clause	Requirement + Test	Result - Remark	Verdict

8.4.3	TABLE: ME EQUIPMENT for connection to a power source by a plug - measurement of voltage or calculation of stored charge 1 s after disconnection of plug from mains supply									N/A
Maximum allowable voltage (V)									60	
Voltage measured (V)										
Voltage Measured Between:	1	2	3	4	5	6	7	8	9	10
Plug pins 1 and 2										
Plug pin 1 and plug earth pin										
Plug pin 2 and plug earth pin										
Plug pin 1 and enclosure										
Plug pin 2 and enclosure										
Maximum allowable stored charge when measured voltage exceeded 60 v (μC)									45	
Calculated stored charge (μC)										
Voltage Measured Between:	1	2	3	4	5	6	7	8	9	10
Plug pins 1 and 2										
Plug pin 1 and plug earth pin										
Plug pin 2 and plug earth pin										
Plug pin 1 and enclosure										
Plug pin 2 and enclosure										
Supplementary information:										

8.4.4	TABLE: Internal capacitive circuits – measurement of residual voltage or calculation of the stored charge in capacitive circuits (i.e., accessible capacitors or circuit parts) after de-energizing ME EQUIPMENT									N/A
Maximum allowable residual voltage (V):									60 V	
Maximum allowable stored charge when residual voltage exceeded 60 V :									45 μC	
Description of the capacitive circuit (i.e., accessible capacitor or circuit parts)	Measured residual voltage (V)	Calculated stored charge (μC)	Remarks							
Supplementary information:										

IEC 60601-1			
Clause	Requirement + Test	Result - Remark	Verdict
8.5.2.2	RM RESULTS TABLE: Type B applied parts		N/A
Clause of ISO 14971	Document Ref. in RMF (Document No. & paragraph)	Result - Remarks	Verdict
4.2			
4.3			
4.4			
5			

8.5.2.3	RM RESULTS TABLE: PATIENT Leads		N/A
Clause of ISO 14971	Document Ref. in RMF (Document No. & paragraph)	Result - Remarks	Verdict
4.2			
4.3			
4.4			
5			

8.5.5.1a	TABLE: defibrillation-proof applied parts – measurement of hazardous electrical energies				N/A
Test Condition: Figs. 9 & 10	Measurement made on accessible part	Applied part with test voltage	Test voltage polarity	Measured voltage between Y1 and Y2 (mV)	Remarks
Supplementary information:					

8.5.5.1b	TABLE: defibrillation-proof applied parts – verification of recovery time				N/A
Applied part with test voltage	Test voltage polarity	Recovery time from documents (s)	Measured recovery time (s)	Remarks	
Supplementary information:					

IEC 60601-1			
Clause	Requirement + Test	Result - Remark	Verdict

8.5.5.2	TABLE: DEFIBRILLATION-PROOF APPLIED PARTS or PATIENT CONNECTIONS of DEFIBRILLATION-PROOF APPLIED PARTS - Energy reduction test –measurement of Energy delivered to a 100 Ω load			N/A
	Test Voltage applied to	Measured Energy E1 (mJ)	Measured Energy E2 (mJ)	Energy E1 as % of E2 (%)
	PATIENT CONNECTION 1 or APPLIED PART with PATIENT CONNECTIONS 2, 3, and 4 of the same APPLIED PART connected to earth			
	PATIENT CONNECTION 2 or APPLIED PART with PATIENT CONNECTIONS 1, 3, and 4 of the same APPLIED PART connected to earth			
	PATIENT CONNECTION 3 or APPLIED PART with PATIENT CONNECTIONS 1, 2, and 4 of the same APPLIED PART connected to earth			
	PATIENT CONNECTION 4 or APPLIED PART with PATIENT CONNECTIONS 1, 2, and 3 of the same APPLIED PART connected to earth			
Supplementary information: For compliance: E1 must at least 90% of E2 E1= Measured energy delivered to 100 Ω with ME Equipment connected; E2= Measured energy delivered to 100 Ω without ME equipment connected.				

8.6.3	RM RESULTS TABLE: Protective earthing of moving parts		N/A
Clause of ISO 14971	Document Ref. in RMF (Document No. & paragraph)	Result - Remarks	Verdict
4.2			
4.3			
4.4			
5			
6.2			
6.3			
6.4			
6.5			

IEC 60601-1			
Clause	Requirement + Test	Result - Remark	Verdict

8.6.4	TABLE: Impedance and current-carrying capability of PROTECTIVE EARTH CONNECTIONS			N/A
Type of ME EQUIPMENT & impedance measured between parts	Test current (A) /Duration (s)	Voltage drop measured between parts (V)	Maximum calculated impedance (mΩ)	Maximum allowable impedance (mΩ)
PERMANENTLY INSTALLED ME EQUIPMENT, impedance between PROTECTIVE EARTH TERMINAL and a PROTECTIVELY EARTHED part				100
ME EQUIPMENT with an APPLIANCE INLET, impedance between earth pin in the APPLIANCE INLET and a PROTECTIVELY EARTHED part				100
ME EQUIPMENT with a non-DETACHABLE POWER SUPPLY CORD, impedance between the protective earth pin in the MAINS PLUG and a PROTECTIVELY EARTHED part				200
Supplementary information:				

IEC 60601-1				
Clause	Requirement + Test	Result - Remark		Verdict
8.7	TABLE: leakage current			P
Type of leakage current and test condition (including single faults)	Supply voltage (V)	Supply frequency (Hz)	Measured max. value (µA)	Remarks
Fig. 13 - Earth Leakage (ER)	—	—	—	Maximum allowed values: 5 mA NC; 10 mA SFC
Fig. 14 - Touch Current (TC)	—	—	—	Maximum allowed values: 100 µA NC; 500 µA SFC
NC, B	6Vdc	--	<5	
NC, A	6Vdc	--	<5	
Fig. 15 - Patient Leakage Current (P)	—	—	—	Maximum allowed values: Type B or BF AP: 10 µA NC; 50 µA SFC (d.c. current); 100 µA NC; 500 µA SFC (a.c.) Type CF AP: 10 µA NC; 50 µA SFC (d.c. or a.c. current)
NC, B	6Vdc	--	<5	
NC, A	6Vdc	--	<5	
Fig. 16 - Patient leakage current with mains on the F-type applied parts (PM)	—	—	—	Maximum allowed values: Type B: N/A Type BF AP: 5000 µA Type CF AP: 50 µA
Fig. 17 - Patient leakage current with external voltage on Signal Input/Output part (SIP/SOP)	—	—	—	Maximum allowed values: Type B or BF AP: 10 µA NC; 50 µA SFC(d.c. current); 100 µA NC; 500 µA SFC (a.c.) ; Type CF AP: 10 µA NC; 50 µA SFC (d.c. or a.c. current)

IEC 60601-1					
Clause	Requirement + Test	Result - Remark			Verdict
Fig. 18 - Patient leakage current with external voltage on metal Accessible Part that is not Protectively Earthed	—	—	—	—	Maximum allowed values: Type B or BF AP: 500 uA Type CF: N/A
Fig. 19 – Patient Auxiliary Current	—	—	—	—	Maximum allowed values: Type B or BF AP: 10 uA NC; 50 uA SFC (d.c. current); 100 uA NC; 500 uA SFC (a.c.) ; Type CF AP: 10 uA NC;50 uA SFC (d.c. or a.c. current)
Fig. 15 and 20 – Total Patient Leakage Current with all AP of same type connected together	—	—	—	—	Maximum allowed values: Type B or BF AP: 50 uA NC; 100uA SFC (d.c. current); 500 uA NC; 1000 uA SFC (a.c.); Type CF AP: 50 uA NC; 100 uA SFC (d.c. or a.c. current)
Fig. 17 and 20 – Total Patient Leakage Current with all AP of same type connected together with external voltage on SIP/SOP	—	—	—	—	Maximum allowed values: Type B or BF AP: 50 uA NC; 100uA SFC (d.c. current); 500 uA NC;1000 uA SFC (a.c.); Type CF AP: 50 uA NC; 100 uA SFC (d.c. or a.c. current)
Fig. 16 and 20 – Total Patient Leakage Current with all AP of same type connected together with external voltage on F-type AP	—	—	—	—	Maximum allowed values: Type B: NA Type BF: 5000uA Type CF: 100 uA

IEC 60601-1					
Clause	Requirement + Test	Result - Remark			Verdict
Fig. 18 and 20 – Total Patient Leakage Current with all AP of same type connected together with external voltage on metal Accessible Part not Protectively Earthed	—	—	—	Maximum allowed values: Type B & BF: 1000 uA Type CF: N/A	
Supplementary information:					
<p>Note 1: For EARTH LEAKAGE CURRENT see 8.7.3 d) and 8.7.4.5; Note 2: For TOUCH CURRENT see 8.7.3 c) and 8.7.4.6; Note 3: For PATIENT LEAKAGE CURRENT SEE 8.7.3.b) and 8.7.4.7 Note 4: Total PATIENT LEAKAGE CURRENT values are only relative to equipment with multiple APPLIED PARTS of the same type. See 8.7.4.7 h). The individual APPLIED PARTS complied with the PATIENT LEAKAGE CURRENT values. Note 5: In addition to conditions indicated in the Table, tests conducted at operating temperature and after humidity preconditioning of 5.7, EQUIPMENT energized in stand-by condition and fully operating, max rated supply frequency, at 110 % of the max RATED MAINS VOLTAGE, and after relevant tests of Clause 11.6 (i.e., overflow, spillage, leakage, ingress of water and particulate matter, cleaning & disinfection, & sterilization).</p>					
ER - Earth leakage current TC – Touch current P - Patient leakage current PA – Patient auxiliary current TP – Total Patient current PM - Patient leakage current with mains on the applied parts MD - Measuring device			A - After humidity conditioning B - Before humidity conditioning 1 - Switch closed or set to normal polarity 0 - Switch open or set to reversed polarity NC - Normal condition SFC - Single fault condition		

8.8.3	TABLE: Dielectric strength test of solid insulating materials with safety function – MEANS OF OPERATOR PROTECTION (MOOP) / MEANS OF PATIENT PROTECTION (MOPP)				P
Insulation under test (area from insulation diagram)	Insulation Type (1 or 2 MOOP/MOPP)	Reference Voltage		A.C. test voltages in V r.m.s. ¹	Dielectric breakdown after 1 minute Yes/No ²
		PEAK WORKING VOLTAGE (U) V _{peak}	PEAK WORKING VOLTAGE (U) V d.c.		
A	2MOPP		6	1000	No
B	2MOPP		6	1000	No
C	2MOPP		6	1000	No
Supplementary information:					
<p>¹ Alternatively, per the Table (i.e., ___dc), a d.c. test voltage equal to the peak value of the a.c. test voltage used. ² A) Immediately after humidity treatment of 5.7, ME EQUIPMENT de-energized, B) after required sterilization PROCEDURE, ME EQUIPMENT de-energized, C) after reaching steady state operating temperature as during heating test of 11.1.1, and D) after relevant tests of 11.6 (i.e., overflow, spillage, leakage, ingress of water, cleaning, disinfection, and sterilization).</p>					

IEC 60601-1			
Clause	Requirement + Test	Result - Remark	Verdict

8.8.4.1	TABLE: Resistance to heat - Ball pressure test of thermoplastic parts		P
	Allowed impression diameter (mm)	≤ 2 mm	—
	Force (N)	20	—
Part/material		Test temperature (°C)	Impression diameter (mm)
Enclosure/External insulating parts		75	1.1
Insulating material supporting uninsulated Mains Parts			
Supplementary information:			

8.8.4.1	RM RESULTS TABLE: Mechanical strength and resistance to heat		N/A
Clause of ISO 14971	Document Ref. in RMF (Document No. & paragraph)	Result - Remarks	Verdict
4.2			
4.3			
4.4			
5			
6.2			
6.3			
6.4			
6.5			

8.9.2	TABLE: Short circuiting of each single one of the CREEPAGE DISTANCES and AIR CLEARANCES for insulation in the MAINS PART between parts of opposite polarity in lieu of complying with the required measurements in 8.9.4		N/A
Specific areas of circuits short-circuited and test conditions	Test in lieu of CREEPAGE DISTANCE OF AIR CLEARANCE¹	HAZARDOUS SITUATION observed (i.e., fire hazard, shock hazard, explosion, discharge of parts, etc.)? Yes/No	Remarks
Supplementary information:			
Note 1: AC - AIR CLEARANCE CD - CREEPAGE DISTANCE			

IEC 60601-1			
Clause	Requirement + Test	Result - Remark	Verdict

8.9.3.2	Table: Thermal cycling tests on one sample of insulating compound forming solid insulation between conductive parts		N/A
Test Sequence No.	Each test duration and temperature	Dielectric test voltage (V = Test voltage in 8.8.3 times 1.6)	Dielectric strength test after humidity preconditioning per cl. 5.7 except for 48 h only, Breakdown: Yes/No
1	68 h at $T1 \pm 2 \text{ }^\circ\text{C} = \text{___ }^\circ\text{C}^1$		
	1 h at $25 \text{ }^\circ\text{C} \pm 2 \text{ }^\circ\text{C}$		
	2 h at $0 \text{ }^\circ\text{C} \pm 2 \text{ }^\circ\text{C}$		
	1 or more h at $25 \text{ }^\circ\text{C} \pm 2 \text{ }^\circ\text{C}$		
2	68 h at $T1 \pm 2 \text{ }^\circ\text{C} = \text{___ }^\circ\text{C}^1$		
	1 h at $25 \text{ }^\circ\text{C} \pm 2 \text{ }^\circ\text{C}$		
	2 h at $0 \text{ }^\circ\text{C} \pm 2 \text{ }^\circ\text{C}$		
	1 or more h at $25 \text{ }^\circ\text{C} \pm 2 \text{ }^\circ\text{C}$		
3	68 h at $T1 \pm 2 \text{ }^\circ\text{C} = \text{___ }^\circ\text{C}^1$		
	1 h at $25 \text{ }^\circ\text{C} \pm 2 \text{ }^\circ\text{C}$		
	2 h at $0 \text{ }^\circ\text{C} \pm 2 \text{ }^\circ\text{C}$		
	1 or more h at $25 \text{ }^\circ\text{C} \pm 2 \text{ }^\circ\text{C}$		
4	68 h at $T1 \pm 2 \text{ }^\circ\text{C} = \text{___ }^\circ\text{C}^1$		
	1 h at $25 \text{ }^\circ\text{C} \pm 2 \text{ }^\circ\text{C}$		
	2 h at $0 \text{ }^\circ\text{C} \pm 2 \text{ }^\circ\text{C}$		
	1 or more h at $25 \text{ }^\circ\text{C} \pm 2 \text{ }^\circ\text{C}$		

Supplementary information:

¹ T1 = 10 °C above the maximum temperature of relevant part determined per 11.1.1, or 85 °C, the higher of the two. 10 °C not added to T1 when temperature measured by an embedded thermocouple. Used gradual transition from one temperature to another.

IEC 60601-1			
Clause	Requirement + Test	Result - Remark	Verdict

8.9.3.4	Table: Thermal cycling tests on one sample of cemented joint (see 8.9.3.3)		N/A
Test Sequence No.	Each test duration and temperature	Dielectric test voltage (V = Test voltage in 8.8.3 times 1.6)	Dielectric strength test after humidity preconditioning per cl. 5.7 except for 48 h only, Breakdown: Yes/No
1	68 h at $T1 \pm 2 \text{ }^\circ\text{C} = \text{ }^\circ\text{C}^1$		
	1 h at $25 \text{ }^\circ\text{C} \pm 2 \text{ }^\circ\text{C}$		
	2 h at $0 \text{ }^\circ\text{C} \pm 2 \text{ }^\circ\text{C}$		
	1 or more h at $25 \text{ }^\circ\text{C} \pm 2 \text{ }^\circ\text{C}$		
2	68 h at $T1 \pm 2 \text{ }^\circ\text{C} = \text{ }^\circ\text{C}^1$		
	1 h at $25 \text{ }^\circ\text{C} \pm 2 \text{ }^\circ\text{C}$		
	2 h at $0 \text{ }^\circ\text{C} \pm 2 \text{ }^\circ\text{C}$		
	1 or more h at $25 \text{ }^\circ\text{C} \pm 2 \text{ }^\circ\text{C}$		
3	68 h at $T1 \pm 2 \text{ }^\circ\text{C} = \text{ }^\circ\text{C}^1$		
	1 h at $25 \text{ }^\circ\text{C} \pm 2 \text{ }^\circ\text{C}$		
	2 h at $0 \text{ }^\circ\text{C} \pm 2 \text{ }^\circ\text{C}$		
	1 or more h at $25 \text{ }^\circ\text{C} \pm 2 \text{ }^\circ\text{C}$		
4	68 h at $T1 \pm 2 \text{ }^\circ\text{C} = \text{ }^\circ\text{C}^1$		
	1 h at $25 \text{ }^\circ\text{C} \pm 2 \text{ }^\circ\text{C}$		
	2 h at $0 \text{ }^\circ\text{C} \pm 2 \text{ }^\circ\text{C}$		
	1 or more h at $25 \text{ }^\circ\text{C} \pm 2 \text{ }^\circ\text{C}$		

Supplementary information:

¹ T1 = 10 °C above the maximum temperature of relevant part determined per 11.1.1, or 85 °C, the higher of the two. 10 °C not added to T1 when temperature measured by an embedded thermocouple. Used gradual transition from one temperature to another.

IEC 60601-1			
Clause	Requirement + Test	Result - Remark	Verdict

8.10	TABLE: List of critical components					P
Component/ Part No.	Manufacturer/ Trademark	Type No./model No./	Technical data	Standard No./, Edition	Mark(s) & Certificates of conformity ¹	
Enclosure	CHI MEI	ABS PA-757	Min. 1.5mm thick, HB	UL 94	UL E56070	
PCB	HUIPUSI	HPS-1	Min. 0.1mm thick, 130degC, V-0	UL 796	UL E330934	
Supplementary information:						
1) An asterisk indicates a mark which assures the agreed level of surveillance. See Licenses and Certificates of Conformity for verification.						

IEC 60601-1			
Clause	Requirement + Test	Result - Remark	Verdict

8.10.1	RM RESULTS TABLE: Fixing of components		N/A
Clause of ISO 14971	Document Ref. in RMF (Document No. & paragraph)	Result - Remarks	Verdict
4.2			
4.3			
4.4			
5			
6.2			
6.3			
6.4			
6.5			

8.10.2	RM RESULTS TABLE: Fixing of wiring		N/A
Clause of ISO 14971	Document Ref. in RMF (Document No. & paragraph)	Result - Remarks	Verdict
4.3			
4.4			
5			
6.2			
6.3			
6.4			
6.5			

8.10.5	RM RESULTS TABLE: Mechanical protection of wiring		N/A
Clause of ISO 14971	Document Ref. in RMF (Document No. & paragraph)	Result - Remarks	Verdict
4.3			
4.4			
5			
6.2			
6.3			
6.4			
6.5			

8.11.3.5	TABLE: Cord anchorages				N/A
Cord under test	Mass of equipment (kg)	Pull (N)	Torque Nm)	Remarks	
Supplementary information:					

IEC 60601-1			
Clause	Requirement + Test	Result - Remark	Verdict
8.11.3.6	TABLE: Cord guard		N/A
Cord under test	Test mass	Measured curvature	Remarks
Supplementary information:			

8.11.5	RM RESULTS TABLE: Mains fuses and over-current releases		N/A
Clause of ISO 14971	Document Ref. in RMF (Document No. & paragraph)	Result - Remarks	Verdict
4.3			
4.4			
5			
6.2			
6.3			
6.4			
6.5			

9.2.1	RM RESULTS TABLE: HAZARDS associated with moving parts - General		N/A
Clause of ISO 14971	Document Ref. in RMF (Document No. & paragraph)	Result - Remarks	Verdict
4.2			
4.3			
4.4			
5			
6.2			
6.3			
6.4			
6.5			

9.2.2.2	TABLE: Measurement of gap "a" according to Table 20 (ISO 13852: 1996)			N/A
Part of body	Allowable adult gap ¹ , mm	Measured adult gap, mm	Allowable children gap ¹ , mm	Measured children gap, mm
Body	> 500		> 500	
Head	> 300 or < 120		> 300 or < 60	
Leg	> 180		> 180	
Foot	> 120 or < 35		> 120 or < 25	
Toes	> 50		> 50	
Arm	> 120		> 120	
Hand, wrist, fist	> 100		> 100	
Finger	> 25 or < 8		> 25 or < 4	

Supplementary information: ¹ In general, gaps for adults used, except when the device is specifically

IEC 60601-1			
Clause	Requirement + Test	Result - Remark	Verdict

designed for use with children, values for children applied.

9.2.2.4.3	RM RESULTS TABLE: Movable guards		N/A
Clause of ISO 14971	Document Ref. in RMF (Document No. & paragraph)	Result - Remarks	Verdict
4.2			
4.3			
4.4			
5			
6.2			
6.3			
6.4			
6.5			

9.2.2.4.4	RM RESULTS TABLE: Protective measures		N/A
Clause of ISO 14971	Document Ref. in RMF (Document No. & paragraph)	Result - Remarks	Verdict
4.2			
4.3			
4.4			
5			
6.2			
6.3			
6.4			
6.5			

9.2.2.5 c)	RM RESULTS TABLE: Continuous activation		N/A
Clause of ISO 14971	Document Ref. in RMF (Document No. & paragraph)	Result - Remarks	Verdict
4.2			
4.3			
4.4			
5			
6.2			
6.3			
6.4			
6.5			

IEC 60601-1			
Clause	Requirement + Test	Result - Remark	Verdict

9.2.2.6	RM RESULTS TABLE: Speed of movement(s)		N/A
Clause of ISO 14971	Document Ref. in RMF (Document No. & paragraph)	Result - Remarks	Verdict
4.2			
4.3			
4.4			
5			
6.2			
6.3			
6.4			
6.5			

9.2.3.2	RM RESULTS TABLE: Over travel		N/A
Clause of ISO 14971	Document Ref. in RMF (Document No. & paragraph)	Result - Remarks	Verdict
4.2			
4.3			
4.4			
5			
6.2			
6.3			
6.4			
6.5			

9.2.4	RM RESULTS TABLE: Emergency stopping devices		N/A
Clause of ISO 14971	Document Ref. in RMF (Document No. & paragraph)	Result - Remarks	Verdict
4.2			
4.3			
4.4			
5			
6.2			
6.3			
6.4			
6.5			
6.6			

IEC 60601-1			
Clause	Requirement + Test	Result - Remark	Verdict

9.2.5	RM RESULTS TABLE: Release of patient		N/A
Clause of ISO 14971	Document Ref. in RMF (Document No. & paragraph)	Result - Remarks	Verdict
4.2			
4.3			
4.4			
5			
6.2			
6.3			
6.4			
6.5			

9.3	RM RESULTS TABLE: Hazards associated with surfaces, corners and edges		N/A
Clause of ISO 14971	Document Ref. in RMF (Document No. & paragraph)	Result - Remarks	Verdict
4.3			
4.4			
5			
6.2			
6.3			
6.4			
6.5			

9.4.2.1	TABLE: Instability—overbalance in transport position		N/A
ME EQUIPMENT preparation	Test Condition (transport position)	Remarks	
Supplementary information:			

9.4.2.2	TABLE: Instability—overbalance excluding transport position		N/A
ME EQUIPMENT preparation	Test Condition (excluding transport position) Test either 5 °incline and verify Warning marking or 10 °incline)	Remarks	
Supplementary information:			

IEC 60601-1			
Clause	Requirement + Test	Result - Remark	Verdict
9.4.2.3	TABLE: Instability—overbalance from horizontal and vertical forces		N/A
ME EQUIPMENT preparation	Test Condition (force used, direction of force, weight of equipment, location of force)	Remarks	
Supplementary information:			

9.4.2.4.2	TABLE: Castors and wheels – Force for propulsion		N/A
ME EQUIPMENT preparation	Test Condition (force location and height)	Remarks	
Supplementary information:			

9.4.2.4.3	TABLE: Castors and wheels – Movement over a threshold		N/A
ME EQUIPMENT preparation	Test Condition (speed of movement)	Remarks	
Supplementary information:			

9.4.2.4.3	RM RESULTS TABLE: Movement over a threshold		N/A
Clause of ISO 14971	Document Ref. in RMF (Document No. & paragraph)	Result - Remarks	Verdict
4.2			
4.3			
4.4			
5			
6.2			
6.3			
6.4			
6.5			

IEC 60601-1			
Clause	Requirement + Test	Result - Remark	Verdict
9.4.3.1	TABLE: Instability from unwanted lateral movement (including sliding) in transport position		N/A
ME EQUIPMENT Preparation	Test Condition (transport position, working load, locking device(s), caster position)	Remarks	
Supplementary information:			

9.4.3.2	TABLE: Instability from unwanted lateral movement (including sliding) excluding transport position		N/A
ME EQUIPMENT Preparation	Test Condition (working load, locking device(s), caster position, force, force location, force direction)	Remarks	
Supplementary information:			

9.4.4	TABLE: Grips and other handling devices		N/A
Clause and Name of Test	Test Condition	Remarks	
Supplementary information:			

9.5.1	RM RESULTS TABLE: Protective means		N/A
Clause of ISO 14971	Document Ref. in RMF (Document No. & paragraph)	Result - Remarks	Verdict
4.3			
4.4			
5			
6.2			
6.3			
6.4			
6.5			

IEC 60601-1			
Clause	Requirement + Test	Result - Remark	Verdict

9.6.1	RM RESULTS TABLE: Acoustic energy - General		N/A
Clause of ISO 14971	Document Ref. in RMF (Document No. & paragraph)	Result - Remarks	Verdict
4.2			
4.3			
4.4			
5			
6.2			
6.3			
6.4			
6.5			

9.6.2.2	RM RESULTS TABLE: Infrasound and ultrasound energy		N/A
Clause of ISO 14971	Document Ref. in RMF (Document No. & paragraph)	Result - Remarks	Verdict
4.2			
4.3			
4.4			
5			
6.2			
6.3			
6.4			
6.5			

9.7.2	RM RESULTS TABLE: Pneumatic and hydraulic parts		N/A
Clause of ISO 14971	Document Ref. in RMF (Document No. & paragraph)	Result - Remarks	Verdict
4.3			
4.4			
5			
6.2			
6.3			
6.4			
6.5			

IEC 60601-1			
Clause	Requirement + Test	Result - Remark	Verdict

9.7.4	RM RESULTS TABLE: Pressure rating of ME equipment parts		N/A
Clause of ISO 14971	Document Ref. in RMF (Document No. & paragraph)	Result - Remarks	Verdict
4.3			
4.4			
5			
6.2			
6.3			
6.4			
6.5			

9.7.5	TABLE: Pressure vessels					N/A
Hydraulic, Pneumatic or Suitable Media and Test Pressure	Vessel Burst	Permanent Deformation	Leaks	Vessel fluid substance	Remarks	

Supplementary Information:

9.7.6	RM RESULTS TABLE: Pressure-control device		N/A
Clause of ISO 14971	Document Ref. in RMF (Document No. & paragraph)	Result - Remarks	Verdict
4.3			
4.4			
5			
6.2			
6.3			
6.4			
6.5			

9.7.7	RM RESULTS TABLE: Pressure-relief device		N/A
Clause of ISO 14971	Document Ref. in RMF (Document No. & paragraph)	Result - Remarks	Verdict
4.3			
4.4			
5			
6.2			

IEC 60601-1			
Clause	Requirement + Test	Result - Remark	Verdict
9.7.7	RM RESULTS TABLE: Pressure-relief device		N/A
Clause of ISO 14971	Document Ref. in RMF (Document No. & paragraph)	Result - Remarks	Verdict
6.3			
6.4			
6.5			
9.8.1	RM RESULTS TABLE: Hazards associated with support systems - General		N/A
Clause of ISO 14971	Document Ref. in RMF (Document No. & paragraph)	Result - Remarks	Verdict
4.2			
4.3			
4.4			
5			
6.2			
6.3			
6.4			
6.5			
9.8.2	RM RESULTS TABLE: Tensile safety factor		N/A
Clause of ISO 14971	Document Ref. in RMF (Document No. & paragraph)	Result - Remarks	Verdict
4.3			
4.4			
5			
6.2			
6.3			
6.4			
6.5			
9.8.3.1	RM RESULTS TABLE: Strength of patient or operator support or suspension systems - General		N/A
Clause of ISO 14971	Document Ref. in RMF (Document No. & paragraph)	Result - Remarks	Verdict
4.2			
4.3			
4.4			
5			
6.2			
6.3			
6.4			
6.5			

IEC 60601-1				
Clause	Requirement + Test	Result - Remark	Verdict	
9.8.3.2	TABLE: PATIENT support/suspension system - Static forces		N/A	
ME EQUIPMENT part or area	Position	Load	Area	Remarks
Supplementary Information:				

9.8.3.2a, b	RM RESULTS TABLE: Static forces due to loading from persons		N/A
Clause of ISO 14971	Document Ref. in RMF (Document No. & paragraph)	Result - Remarks	Verdict
4.3			
4.4			
5			
6.2			
6.3			
6.4			
6.5			

9.8.3.3	TABLE: Support/Suspension System – Dynamic forces due to loading from persons			N/A
ME EQUIPMENT part or area	Position	Safe Working Load	Area	Remarks
Supplementary Information:				

9.8.4.1	RM RESULTS TABLE: Systems with mechanical protective devices - General		N/A
Clause of ISO 14971	Document Ref. in RMF (Document No. & paragraph)	Result - Remarks	Verdict
4.3			
4.4			
5			
6.2			
6.3			
6.4			
6.5			

IEC 60601-1			
Clause	Requirement + Test	Result - Remark	Verdict

9.8.4.3	RM RESULTS TABLE: Mechanical protective device for single activation		N/A
Clause of ISO 14971	Document Ref. in RMF (Document No. & paragraph)	Result - Remarks	Verdict
4.3			
4.4			
5			
6.2			
6.3			
6.4			
6.5			

9.8.5	RM RESULTS TABLE: Systems without mechanical protective devices		N/A
Clause of ISO 14971	Document Ref. in RMF (Document No. & paragraph)	Result - Remarks	Verdict
4.3			
4.4			
5			
6.2			
6.3			
6.4			
6.5			

10.1.1	TABLE: Measurement of X - radiation		N/A
Maximum allowable radiation pA/kg (μSv/h) (mR/h)		36 (5 μSv/h) (0.5 mR/h)	
Surface area under test Surface no./ Description ¹		Measured Radiation, pA/kg (μSv/h) (mR/h)	Remarks
1/ /			
2/ /			
3/ /			
4/ /			
5/ /			
6/ /			
7/ /			
8/ /			
9/ /			
10/ /			

Supplementary information: ¹ Measurements made at a distance of 5 cm from any surface to which OPERATOR (other than SERVICE PERSONNEL) can gain access without a TOOL, is deliberately provided with means of access, or is instructed to enter regardless of whether or not a TOOL is needed to gain access

IEC 60601-1			
Clause	Requirement + Test	Result - Remark	Verdict

10.1.2	RM RESULTS TABLE: ME equipment intended to produce diagnostic or therapeutic X-radiation		N/A
Clause of ISO 14971	Document Ref. in RMF (Document No. & paragraph)	Result - Remarks	Verdict
4.2			
4.3			
4.4			
5			
6.2			
6.3			
6.4			
6.5			

10.2	RM RESULTS TABLE: Alpha, beta, gamma, neutron & other particle radiation		N/A
Clause of ISO 14971	Document Ref. in RMF (Document No. & paragraph)	Result - Remarks	Verdict
4.2			
4.3			
4.4			
5			
6.2			
6.3			
6.4			
6.5			

10.3	RM RESULTS TABLE: Microwave radiation		N/A
Clause of ISO 14971	Document Ref. in RMF (Document No. & paragraph)	Result - Remarks	Verdict
4.2			
4.3			
4.4			
5			
6.2			
6.3			
6.4			
6.5			

IEC 60601-1			
Clause	Requirement + Test	Result - Remark	Verdict

10.5	RM RESULTS TABLE: Other visible electromagnetic radiation		N/A
Clause of ISO 14971	Document Ref. in RMF (Document No. & paragraph)	Result - Remarks	Verdict
4.2			
4.3			
4.4			
5			
6.2			
6.3			
6.4			
6.5			

10.6	RM RESULTS TABLE: Risk associated with infrared radiation other than emitted by lasers and LEDs		N/A
Clause of ISO 14971	Document Ref. in RMF (Document No. & paragraph)	Result - Remarks	Verdict
4.2			
4.3			
4.4			
5			
6.2			
6.3			
6.4			
6.5			

10.7	RM RESULTS TABLE: Risk associated with ultraviolet radiation other than emitted by lasers and LEDs		N/A
Clause of ISO 14971	Document Ref. in RMF (Document No. & paragraph)	Result - Remarks	Verdict
4.2			
4.3			
4.4			
5			
6.2			
6.3			
6.4			
6.5			

IEC 60601-1			
Clause	Requirement + Test	Result - Remark	Verdict

11.1.1			TABLE: Excessive temperatures in ME EQUIPMENT			P
Model No..... :		TS1011				
Test ambient (°C)		25				
Test supply voltage/frequency (V/Hz) ⁴ .. :		6Vdc				
Model No.	Thermo-couple No.	Thermocouple location ³	Max allowable temperature ¹ from Table 22, 23 or 24 or RM file for AP ⁵ (°C)	Max measured temperature ² , (°C)	Remarks	
TS1011	001	Enclosure / applied part		26		
TS1011	002	PCB		29		
TS1011	003	U1		32		
TS1011	004	Battery		26		
	005	Ambient		25		

Supplementary information:

¹ Maximum allowable temperature on surfaces of test corner is 90 °C

² Max temperature determined in accordance with 11.1.3e)

³ When thermocouples used to determine temperature of windings, limits of Table 22 reduced by 10 °C.

⁴ Supply voltage:

- ME EQUIPMENT with heating elements - 110 % of the maximum RATED voltage;
- Motor operated ME EQUIPMENT - least favourable voltage between 90 % of the minimum RATED and 110 % of the maximum RATED voltage. ME EQUIPMENT operated under normal load and normal DUTY CYCLE.
- Combined heating and motor operated and other ME EQUIPMENT - tested both at 110 % of the maximum RATED voltage and at 90 % of the minimum RATED voltage.

⁵ APPLIED PARTS intended to supply heat to a PATIENT - See RISK MANAGEMENT FILE containing temperatures and clinical effects. Also, see instructions for use.

IEC 60601-1			
Clause	Requirement + Test	Result - Remark	Verdict

11.1.1	RM RESULTS TABLE: Maximum temperature during normal use (Table 23 or 24)		N/A
Clause of ISO 14971	Document Ref. in RMF (Document No. & paragraph)	Result - Remarks	Verdict
4.2			
4.3			
4.4			
5			
6.2			
6.3			
6.4			
6.5			

11.1.2.1	RM RESULTS TABLE: Applied parts intended to supply heat to patient		N/A
Clause of ISO 14971	Document Ref. in RMF (Document No. & paragraph)	Result - Remarks	Verdict
4.2			
4.3			
4.4			
5			
6.2			
6.3			
6.4			
6.5			

11.1.2.2	RM RESULTS TABLE: Applied parts not intended to supply heat to patient		N/A
Clause of ISO 14971	Document Ref. in RMF (Document No. & paragraph)	Result - Remarks	Verdict
4.2			
4.3			
4.4			
5			
6.2			
6.3			
6.4			
6.5			

IEC 60601-1			
Clause	Requirement + Test	Result - Remark	Verdict

11.1.3	TABLE: Temperature of windings by change-of-resistance method						N/A
Temperature T of winding:	t ₁ (°C)	R ₁ (Ω)	t ₂ (°C)	R ₂ (Ω)	T (°C)	Allowed T _{max} (°C)	Insulation class
Supplementary information:							

11.1.3	RM RESULTS TABLE: Measurements		N/A
Clause of ISO 14971	Document Ref. in RMF (Document No. & paragraph)	Result - Remarks	Verdict
4.2			
4.3			
4.4			
5			
6.2			
6.3			
6.4			
6.5			

11.2.2.1	RM RESULTS TABLE: Risk of fire in an oxygen rich environment		N/A
Clause of ISO 14971	Document Ref. in RMF (Document No. & paragraph)	Result - Remarks	Verdict
4.2			
4.3			
4.4			
5			
6.2			
6.3			
6.4			
6.5			

IEC 60601-1			
Clause	Requirement + Test	Result - Remark	Verdict

11.2.2.1	TABLE: Alternative method to 11.2.2.1 a) 5) to determine existence of an ignition source		N/A
Areas where sparking might cause ignition:			Remarks
1.			
2.			
3.			
5.			
6.			
Materials of the parts between which sparks could occur (Composition, Grade Designation, Manufacturer):			Remarks
1.			
2.			
3.			
4.			
5.			
6.			
Test parameters selected representing worst case conditions for ME EQUIPMENT:			Remarks
Oxygen concentration (%):			
Fuel :			
Current (A) :			
Voltage (V) :			
Capacitance (μF) :			
Inductance or resistance (h or Ω):			
No. of trials (300 Min) :			
Sparks resulted in ignition (Yes/No) :			
Supplementary information:			
Test procedure of 11.2.2.1 a) 5) & Figs 35-37 used for tests. For circuits not in Figs 35-37, test voltage or current set at 3 times the worst case values with other parameters set at worst case values to determine if ignition can occur.			

IEC 60601-1			
Clause	Requirement + Test	Result - Remark	Verdict

11.3	RM RESULTS TABLE: Constructional requirements for fire enclosures of ME equipment		N/A
Clause of ISO 14971	Document Ref. in RMF (Document No. & paragraph)	Result - Remarks	Verdict
4.2			
4.3			
4.4			
5			
6.2			
6.3			
6.4			
6.5			

11.5	RM RESULTS TABLE: ME equipment and ME systems intended for use in conjunction with flammable agents		N/A
Clause of ISO 14971	Document Ref. in RMF (Document No. & paragraph)	Result - Remarks	Verdict
4.2			
4.3			
4.4			
5			
6.2			
6.3			
6.4			
6.5			

11.6.1	TABLE: overflow, spillage, leakage, ingress of water, cleaning, disinfection, sterilization, compatibility with substances			P
Clause / Test Name	Test Condition	Part under test	Remarks	
Cleaning test / clause 11.6.6	Cleaning according to manual	Entire EUT	Leakage test and dielectric strength test performed afterwards	
Supplementary information:				

IEC 60601-1			
Clause	Requirement + Test	Result - Remark	Verdict

11.6.2	RM RESULTS TABLE: Overflow in ME equipment		N/A
Clause of ISO 14971	Document Ref. in RMF (Document No. & paragraph)	Result - Remarks	Verdict
4.2			
4.3			
4.4			
5			

11.6.3	RM RESULTS TABLE: Spillage on ME equipment and ME system		N/A
Clause of ISO 14971	Document Ref. in RMF (Document No. & paragraph)	Result - Remarks	Verdict
4.2			
4.3			
4.4			
5			
6.2			
6.3			
6.4			
6.5			

11.6.5	RM RESULTS TABLE: Ingress of water or particulate matter into ME EQUIPMENT and ME SYSTEMS		N/A
Clause of ISO 14971	Document Ref. in RMF (Document No. & paragraph)	Result - Remarks	Verdict
4.2			
4.3			
4.4			
5			

11.6.6	RM RESULTS TABLE: Cleaning and disinfection of ME equipment and ME systems		N/A
Clause of ISO 14971	Document Ref. in RMF (Document No. & paragraph)	Result - Remarks	Verdict
4.2			
4.3			
4.4			
5			
6.2			
6.3			
6.4			
6.5			

IEC 60601-1			
Clause	Requirement + Test	Result - Remark	Verdict

11.6.7	RM RESULTS TABLE: Sterilization of ME equipment and ME systems		N/A
Clause of ISO 14971	Document Ref. in RMF (Document No. & paragraph)	Result - Remarks	Verdict
4.2			
4.3			
4.4			
5			
6.2			
6.3			
6.4			
6.5			

11.6.8	RM RESULTS TABLE: Compatibility with substances used		N/A
Clause of ISO 14971	Document Ref. in RMF (Document No. & paragraph)	Result - Remarks	Verdict
4.2			
4.3			
4.4			
5			
6.2			
6.3			
6.4			
6.5			

12.1	RM RESULTS TABLE: Accuracy of controls and equipment		N/A
Clause of ISO 14971	Document Ref. in RMF (Document No. & paragraph)	Result - Remarks	Verdict
4.2			
4.3			
4.4			
5			
6.2			
6.3			
6.4			
6.5			

IEC 60601-1			
Clause	Requirement + Test	Result - Remark	Verdict

12.3	RM RESULTS TABLE: Alarm systems		N/A
Clause of ISO 14971	Document Ref. in RMF (Document No. & paragraph)	Result - Remarks	Verdict
4.2			
4.3			
4.4			
5			
6.2			
6.3			
6.4			
6.5			

12.4.1	RM RESULTS TABLE: Intentional exceeding of safety limits		N/A
Clause of ISO 14971	Document Ref. in RMF (Document No. & paragraph)	Result - Remarks	Verdict
4.2			
4.3			
4.4			
5			
6.2			
6.3			
6.4			
6.5			

12.4.2	RM RESULTS TABLE: Indication of parameters relevant to safety		N/A
Clause of ISO 14971	Document Ref. in RMF (Document No. & paragraph)	Result - Remarks	Verdict
4.2			
4.3			
4.4			
5			
6.2			
6.3			
6.4			
6.5			

IEC 60601-1			
Clause	Requirement + Test	Result - Remark	Verdict

12.4.3	RM RESULTS TABLE: Accidental selection of excessive output values		N/A
Clause of ISO 14971	Document Ref. in RMF (Document No. & paragraph)	Result - Remarks	Verdict
4.2			
4.3			
4.4			
5			
6.2			
6.3			
6.4			
6.5			

12.4.4	RM RESULTS TABLE: Incorrect output		N/A
Clause of ISO 14971	Document Ref. in RMF (Document No. & paragraph)	Result - Remarks	Verdict
4.2			
4.3			
4.4			
5			
6.2			
6.3			
6.4			
6.5			

12.4.5.2	RM RESULTS TABLE: Diagnostic X-ray equipment		N/A
Clause of ISO 14971	Document Ref. in RMF (Document No. & paragraph)	Result - Remarks	Verdict
4.2			
4.3			
4.4			
5			
6.2			
6.3			
6.4			
6.5			

IEC 60601-1			
Clause	Requirement + Test	Result - Remark	Verdict

12.4.5.3	RM RESULTS TABLE: Radiotherapy equipment		N/A
Clause of ISO 14971	Document Ref. in RMF (Document No. & paragraph)	Result - Remarks	Verdict
4.2			
4.3			
4.4			
5			
6.2			
6.3			
6.4			
6.5			

12.4.5.4	RM RESULTS TABLE: Other ME equipment producing diagnostic or therapeutic radiation		N/A
Clause of ISO 14971	Document Ref. in RMF (Document No. & paragraph)	Result - Remarks	Verdict
4.2			
4.3			
4.4			
5			
6.2			
6.3			
6.4			
6.5			

12.4.6	RM RESULTS TABLE: Diagnostic or therapeutic acoustic pressure		N/A
Clause of ISO 14971	Document Ref. in RMF (Document No. & paragraph)	Result - Remarks	Verdict
4.2			
4.3			
4.4			
5			
6.2			
6.3			
6.4			
6.5			

IEC 60601-1			
Clause	Requirement + Test	Result - Remark	Verdict

13.1.2	TABLE: measurement of power or energy dissipation in parts & components to waive SINGLE FAULT CONDITIONS in 4.7, 8.1 b), 8.7.2, and 13.2.2 relative to emission of flames, molten metal, or ignitable substances			N/A
Power dissipated less than (W)		15		
Energy dissipated less than (J)		900		
Part or component tested	Measured power dissipated (W)	Calculated energy dissipated (J)	SINGLE FAULT CONDITIONS waived (Yes/No)	Remarks
Supplementary information:				

13.2	TABLE: SINGLE FAULT CONDITIONS in accordance with 13.2.2 to 13.2.13, inclusive			P
Clause No.	Description of SINGLE FAULT CONDITION	Results observed	HAZARDOUS SITUATION (Yes/No)	
13.2.2	Electrical SINGLE FAULT CONDITIONS per Clause 8.1:	—	—	
	Opposite polarity of battery	No high temperature	No	
	U1 pin shorted	No output	No	
13.2.3	Overheating of transformers per Clause 15.5:	—	—	

IEC 60601-1			
Clause	Requirement + Test	Result - Remark	Verdict
Clause No.	Description of SINGLE FAULT CONDITION	Results observed	HAZARDOUS SITUATION (Yes/No)
13.2.4	Failure of THERMOSTATS according to 13.2.13 & 15.4.2, overloading - THERMOSTATS short circuited or interrupted, the less favourable of the two:	—	—
13.2.5	Failure of temperature limiting devices according to 13.2.13 & 15.4.2, overloading, THERMOSTATS short circuited or interrupted, the less favourable of the two:	—	—
13.2.6	Leakage of liquid - RISK MANAGEMENT FILE examined to determine the appropriate test conditions (sealed rechargeable batteries exempted)	—	—
13.2.7	Impairment of cooling that could result in a HAZARD using test method of 11.1:	—	—
	Single ventilation fans locked consecutively		
	Ventilation openings on top and sides impaired by covering openings on top of ENCLOSURE or positioning of ME EQUIPMENT against walls		
	Simulated blocking of filters		
	Flow of a cooling agent interrupted		
13.2.8	Locking of moving parts – Only one part locked at a time – Also see 13.2.10 below:	—	—
13.2.9	Interruption and short circuiting of motor capacitors – Motor capacitors short & open circuited ¹ – Also see 13.10	—	—
		V measured =	
		V measured =	

IEC 60601-1			
Clause	Requirement + Test	Result - Remark	Verdict
Clause No.	Description of SINGLE FAULT CONDITION	Results observed	HAZARDOUS SITUATION (Yes/No)
13.2.10	Additional test criteria for motor operated ME EQUIPMENT in 13.2.8 & 13.2.9:	—	—
	For every test in SINGLE FAULT CONDITION of 13.2.8 and 13.2.9, motor-operated EQUIPMENT started from COLD CONDITION at RATED voltage or at the upper limit of RATED voltage range for specified time:		
	Temperatures of windings determined at the end of specified test periods or at the instant of operation of fuses, THERMAL CUT-OUTS, motor protective devices		
	Temperatures measured as specified in 11.1.3 d)		
	Temperatures did not exceed limits of Table 26		
13.2.11	Failures of components in ME EQUIPMENT used in conjunction with OXYGEN RICH ENVIRONMENTS:	—	—
13.2.12	Failure of parts that might result in a MECHANICAL HAZARD (See 9 & 15.3):	—	—
Supplementary information:			
¹ Test with short-circuited capacitor not performed when motor provided with a capacitor complying with IEC 60252-1 and the ME EQUIPMENT not intended for unattended use including automatic or remote control. See Attachment # and appended Table 8.10.			

13.2.6	RM RESULTS TABLE: Leakage of liquid		N/A
Clause of ISO 14971	Document Ref. in RMF (Document No. & paragraph)	Result - Remarks	Verdict
4.2			
4.3			
4.4			
5			
6.2			
6.3			
6.4			
6.5			

IEC 60601-1			
Clause	Requirement + Test	Result - Remark	Verdict
14.1	RM RESULTS TABLE: Programmable electrical medical systems - General		N/A
Clause of ISO 14971	Document Ref. in RMF (Document No. & paragraph)	Result - Remarks	Verdict
4.2			
4.3			
4.4			
5			
14.6.1	RM RESULTS TABLE: Identification of known and foreseeable hazards		N/A
Clause of ISO 14971	Document Ref. in RMF (Document No. & paragraph)	Result - Remarks	Verdict
4.3			
14.6.2	RM RESULTS TABLE: Risk control		N/A
Clause of ISO 14971	Document Ref. in RMF (Document No. & paragraph)	Result - Remarks	Verdict
6.1			
14.7	RM RESULTS TABLE: Requirement specification		N/A
Clause of ISO 14971	Document Ref. in RMF (Document No. & paragraph)	Result - Remarks	Verdict
6.3			
14.8	RM RESULTS TABLE: Architecture		N/A
Clause of ISO 14971	Document Ref. in RMF (Document No. & paragraph)	Result - Remarks	Verdict
6.3			
14.9	RM RESULTS TABLE: Design and Implementation		N/A
Clause of ISO 14971	Document Ref. in RMF (Document No. & paragraph)	Result - Remarks	Verdict
6.2			
6.3			
14.10	RM RESULTS TABLE: Verification		N/A
Clause of ISO 14971	Document Ref. in RMF (Document No. & paragraph)	Result - Remarks	Verdict
6.3			
14.11	RM RESULTS TABLE: PEMS validation		N/A
Clause of ISO 14971	Document Ref. in RMF (Document No. & paragraph)	Result - Remarks	Verdict
6.3			

IEC 60601-1			
Clause	Requirement + Test	Result - Remark	Verdict

14.13	RM RESULTS TABLE: Connection of PEMS by NETWORK/DATA COUPLING to other equipment		N/A
Clause of ISO 14971	Document Ref. in RMF (Document No. & paragraph)	Result - Remarks	Verdict
4.2			
4.3			
4.4			
5			
6.2			
6.3			

15.1	RM RESULTS TABLE: Construction of ME equipment – Arrangements of controls and indicators of ME equipment		N/A
Clause of ISO 14971	Document Ref. in RMF (Document No. & paragraph)	Result - Remarks	Verdict
4.2			
4.3			
4.4			
5			
6.2			
6.3			
6.4			
6.5			

15.3	TABLE: Mechanical Strength tests ¹⁾		P
Clause	Name of Test	Test conditions	Observed results/Remarks
15.3.2	Push Test	Force = 250 N ± 10 N for 5 s	No damage, no hazard
15.3.3	Impact Test	Steel ball (50 mm in dia., 500 g ± 25 g) falling from a 1.3 m	No damage, no hazard
15.3.4.1	Drop Test (hand-held)	Free fall height (m) =	
15.3.4.2	Drop Test (portable)	Drop height (cm) = 5	No damage, no hazard
15.3.5	Rough handling test	Travel speed (m/s) =	
15.3.6	Mould Stress Relief	7 h in oven at temperature (°C) = 70	No damage, no hazard

Supplementary information: ¹⁾As applicable, Push, Impact, Drop, Mould Stress Relief and Rough Handling Tests (delete not applicable rows).

IEC 60601-1			
Clause	Requirement + Test	Result - Remark	Verdict

15.3.2	RM RESULTS TABLE: Push test		N/A
Clause of ISO 14971	Document Ref. in RMF (Document No. & paragraph)	Result - Remarks	Verdict
4.2			
4.3			
4.4			
5			

15.3.3	RM RESULTS TABLE: Impact test		N/A
Clause of ISO 14971	Document Ref. in RMF (Document No. & paragraph)	Result - Remarks	Verdict
4.2			
4.3			
4.4			
5			

15.3.4.2	RM RESULTS TABLE: Portable ME equipment		N/A
Clause of ISO 14971	Document Ref. in RMF (Document No. & paragraph)	Result - Remarks	Verdict
4.2			
4.3			
4.4			
5			

15.3.5	RM RESULTS TABLE: Rough handling test		N/A
Clause of ISO 14971	Document Ref. in RMF (Document No. & paragraph)	Result - Remarks	Verdict
4.2			
4.3			
4.4			
5			

15.4.1	RM RESULTS TABLE: Construction of connectors		N/A
Clause of ISO 14971	Document Ref. in RMF (Document No. & paragraph)	Result - Remarks	Verdict
4.2			
4.3			
4.4			
5			
6.2			
6.3			
6.4			
6.5			

IEC 60601-1			
Clause	Requirement + Test	Result - Remark	Verdict

15.4.2.1 a	RM RESULTS TABLE: THERMAL CUT-OUTS and OVER-CURRENT RELEASES		N/A
Clause of ISO 14971	Document Ref. in RMF (Document No. & paragraph)	Result - Remarks	Verdict
4.2			
4.3			
4.4			
5			

15.4.2.1 b	RM RESULTS TABLE: THERMAL CUT-OUTS with a safety function		N/A
Clause of ISO 14971	Document Ref. in RMF (Document No. & paragraph)	Result - Remarks	Verdict
4.2			
4.3			
4.4			

15.4.2.1 c	RM RESULTS TABLE: Independent non-SELF-RESETTING THERMAL CUT-OUT		N/A
Clause of ISO 14971	Document Ref. in RMF (Document No. & paragraph)	Result - Remarks	Verdict
4.2			
4.3			
4.4			

15.4.2.1 d	RM RESULTS TABLE: Loss of function of ME EQUIPMENT		N/A
Clause of ISO 14971	Document Ref. in RMF (Document No. & paragraph)	Result - Remarks	Verdict
4.2			
4.3			
4.4			

15.4.2.1 h	RM RESULTS TABLE: ME EQUIPMENT with tubular heating elements		N/A
Clause of ISO 14971	Document Ref. in RMF (Document No. & paragraph)	Result - Remarks	Verdict
4.2			
4.3			
4.4			

15.4.3.1	RM RESULTS TABLE: Housing		N/A
Clause of ISO 14971	Document Ref. in RMF (Document No. & paragraph)	Result - Remarks	Verdict
4.2			
4.3			
4.4			

IEC 60601-1			
Clause	Requirement + Test	Result - Remark	Verdict
15.4.3.2	RM RESULTS TABLE: Connection		N/A
Clause of ISO 14971	Document Ref. in RMF (Document No. & paragraph)	Result - Remarks	Verdict
4.2			
4.3			
4.4			
15.4.3.3	RM RESULTS TABLE: Protection against overcharging		N/A
Clause of ISO 14971	Document Ref. in RMF (Document No. & paragraph)	Result - Remarks	Verdict
4.2			
4.3			
4.4			
15.4.3.4	RM RESULTS TABLE: Lithium batteries		N/A
Clause of ISO 14971	Document Ref. in RMF (Document No. & paragraph)	Result - Remarks	Verdict
4.2			
4.3			
4.4			
15.4.3.5	RM RESULTS TABLE: Excessive current and voltage protection		N/A
Clause of ISO 14971	Document Ref. in RMF (Document No. & paragraph)	Result - Remarks	Verdict
4.2			
4.3			
4.4			
5			
6.2			
6.3			
6.4			
6.5			
15.4.4	RM RESULTS TABLE: Indicators		N/A
Clause of ISO 14971	Document Ref. in RMF (Document No. & paragraph)	Result - Remarks	Verdict
4.2			
4.3			
4.4			

IEC 60601-1			
Clause	Requirement + Test	Result - Remark	Verdict

15.4.5	RM RESULTS TABLE: Pre-set controls		N/A
Clause of ISO 14971	Document Ref. in RMF (Document No. & paragraph)	Result - Remarks	Verdict
4.2			
4.3			
4.4			
5			
6.2			
6.3			
6.4			
6.5			

15.4.6	TABLE: actuating parts of controls of ME EQUIPMENT – torque & axial pull tests					N/A
Rotating control under test	Gripping diameter “d” of control knob (mm) ¹	Torque from Table 30 (Nm)	Axial force applied (N)	Unacceptable RISK occurred Yes/No	Remarks	

Supplementary information: ¹ Gripping diameter (d) is the maximum width of a control knob regardless of its shape (e.g. control knob with pointer)

15.4.7.3 b	RM RESULTS TABLE: Entry of liquids		N/A
Clause of ISO 14971	Document Ref. in RMF (Document No. & paragraph)	Result - Remarks	Verdict
4.2			
4.3			
4.4			

IEC 60601-1			
Clause	Requirement + Test	Result - Remark	Verdict

15.5.1.2	TABLE: transformer short circuit test short-circuit applied at end of windings or at the first point that could be short circuited under SINGLE FAULT CONDITION						N/A
Primary voltage (most adverse value from 90 % to 110 % of RATED voltage)(V)¹ :						—	
RATED input frequency (Hz)..... :						—	
Winding tested	Class of insulation (A, B, E, F, or H)	Type of protective device (fuse, circuit breaker) /Ratings	Protective device operated Yes/No	Time to THERMAL STABILITY (when protective device did not operate)(Min)	Maximum allowed temp from Table 31 (°C)	Maximum winding temp measured (°C)	Ambient (°C)
Supplementary information: ¹ Loads on other windings between no load and their NORMAL USE load. Short-circuit applied at end of windings or at the first point that could be short circuited under SINGLE FAULT CONDITION.							

15.5.1.3	TABLE: transformer overload test – conducted only when protective device under short-circuit test operated						N/A
Primary voltage, most adverse value between 90 % to 110 % of RATED voltage (V)¹ :							
RATED input frequency (Hz)..... :							
Test current just below minimum current that would activate protective device & achieve THERMAL STABILITY under method a) (A)..... :							
Test current based on Table 32 when protective device that operated under method a) is external to transformer, and it was shunted (A)..... :							
Winding tested	Class of insulation (A, B, E, F, H)	Type of protective device used (fuse, circuit breaker)/Ratings	Maximum allowed temp from Table 31 (°C)	Maximum winding temp measured (°C)	Ambient (°C)		
Supplementary information: ¹ Loads on other windings between no load and their NORMAL USE load. Time durations: - IEC 60127-1 fuse: 30 min at current from Table 32. Non IEC 60127-1 fuse: 30 min at the current based on characteristics supplied by fuse manufacturer, specifically, 30 min clearing-time current. When no 30 min clearing-time current data available, test current from Table 32 used until THERMAL STABILITY achieved. - Other types of protective devices: until THERMAL STABILITY achieved at a current just below minimum current operating the protective device in a). This portion concluded at specified time or when a second protective device opened.							

IEC 60601-1			
Clause	Requirement + Test	Result - Remark	Verdict

15.5.2	TABLE: Transformer dielectric strength after humidity preconditioning of 5.7				N/A
Transformer Model/Type/ Part No	Test voltage applied between	Test voltage, (V)	Test frequency (Hz)	Breakdown Yes/No	Deterioration Yes/No
	Primary & secondary windings				
	Primary winding & frame				
	Secondary winding & frame				

Supplementary information: Tests conducted under the conditions of 11.1, in ME EQUIPMENT or under simulated conditions on the bench. See Clause 15.5.2 for test parameters & other details

16.1	RM RESULTS TABLE: General requirements for ME Systems		N/A
Clause of ISO 14971	Document Ref. in RMF (Document No. & paragraph)	Result - Remarks	Verdict
4.2			
4.3			
4.4			
5			

16.6.1	TABLE: LEAKAGE CURRENTS in ME SYSTEM _ TOUCH CURRENT MEASUREMENTS				N/A
Specific area where TOUCH CURRENT measured (i.e., from or between parts of ME SYSTEM within PATIENT ENVIRONMENT)	Allowable TOUCH CURRENT in NORMAL CONDITION (μ A)	Measured TOUCH CURRENT in NORMAL CONDITION (μ A)	Allowable TOUCH CURRENT in event of interruption of PROTECTIVE EARTH CONDUCTOR, (μ A)	Measured TOUCH CURRENT in event of interruption of PROTECTIVE EARTH CONDUCTOR, (μ A)	
	100		500		
	100		500		
	100		500		
	100		500		
	100		500		

Supplementary information:

IEC 60601-1			
Clause	Requirement + Test	Result - Remark	Verdict

16.9.1	RM RESULTS TABLE: Connection terminals and connectors		N/A
Clause of ISO 14971	Document Ref. in RMF (Document No. & paragraph)	Result - Remarks	Verdict
4.2			
4.3			
4.4			
5			
6.2			
6.3			
6.4			
6.5			

17	RM RESULTS TABLE: Electromagnetic compatibility of ME equipment and ME systems		N/A
Clause of ISO 14971	Document Ref. in RMF (Document No. & paragraph)	Result - Remarks	Verdict
4.2			
4.3			
4.4			
5			
6.2			
6.3			
6.4			
6.5			

SP	TABLE: Additional or special tests conducted		N/A
Clause and Name of Test	Test type and condition	Observed results	
Supplementary information:			

IEC 60601-1			
Clause	Requirement + Test	Result - Remark	Verdict

ATTACHMENT PHOTO OF EUT



IEC 60601-1			
Clause	Requirement + Test	Result - Remark	Verdict

ATTACHMENT PHOTO OF EUT

